

Volumetric Filter

ULTIMATE FILTER PERFORMANCE

For residential and semi-commercial pools



 **Emaux**
water technology

Pool & Spa Equipment

SIGNATURE COLLECTION

Product Features

Tank Material

HDPE

Max Operating Pressure

58 psi / 4 bar

Max Temperature

50°C (122°F)

Suggested Size of Media

0.5-0.8mm

Advantages

Better Water: 30% more volume of filtration bed among other filters in the market to improve the filtration quality.

Less Backwash: The high volume of filtration bed allows the filter to trap more dirt and as a result, less frequency of backwash is required.

User-friendly: Easy to install, maintain and replace. Affordable spare parts available.

High compatibility: The filter and its components are compatible in all different kinds of pool applications.

Robust Performance: HDPE filter body provide the best protection under any extreme weather conditions.

Volumetric Filter is equipped with:

1. 6-way clamp style multiport valve (1.5"MPV07, 2"MPV08)
2. universal standard of union connection
3. pressure gauge
4. ABS lateral system

Model:
T450



Model:
T500

Volumetric Filter

ENGINEERED FOR THE DIFFERENCES

One-piece blow-molded filter tank combining the technology of structural engineered high-density polyethylene material manufactured to maximize the strength of the filter. It is perfectly suited for all pools with different disinfection systems (Salt chlorinator , Ozone, UV, and chemical dosing).

The Volumetric Filter is engineered for the best clarity of filtered water and an outstanding pressure standard among the market benchmarks.

The filter incorporates a multiport valve manufactured from robust components to create the most efficient, reliable, and user-friendly filter with the best value for money positioning in the market.

Professional approach of creating better water

-
1. Unique multiport valve design allows tool-free maintenance and operation
 2. 30% higher of filtration bed for a deeper water filtration, better water quality, and less backwash
 3. The cover of the drain can be used as a tool for opening filter parts
 4. Hinged clamp allows a 360° rotation of valve to simplify installation and plumbing works
 5. Innovative T-shaped filter tank is designed for better backwashing. Tank in HDPE material can withstand higher pressured water temperature
 6. Double-Layered lateral system benefits uniform movement of water collection and allows more complete and efficient backwashing

Product Dimension:

Model	A mm	B mm	C mm
T450	964	457	353
T500	1040	508	400
T600	1090	610	457
T700	1180	711	516
T600B	1142	610	457
T700B	1232	711	516

Technical Information

Code	Model	Filter Area (m ²)	Valve Connections	Max Flow Rate	Sand (kg)
88016003	T450	0.16	1.5" / 50mm	8.0m ³ /h	75
88016004	T500	0.20	1.5" / 50mm	10.0m ³ /h	95
88016046	T600	0.29	1.5" / 50mm	14.6m ³ /h	165
88016007	T700	0.39	1.5" / 50mm	19.5m ³ /h	200
88016047	T600B	0.29	2.0" / 63mm	14.6m ³ /h	165
88016008	T700B	0.39	2.0" / 63mm	19.5m ³ /h	200

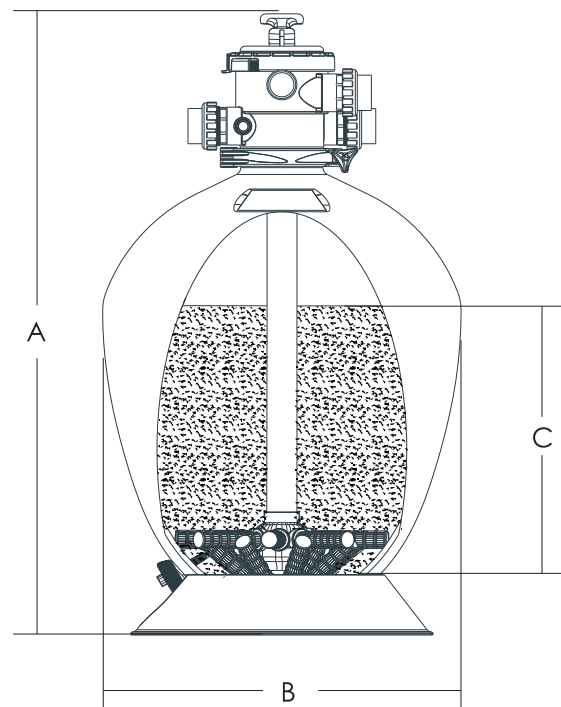

EMAUX WATER TECHNOLOGY CO., LTD

ADDRESS: Flat A-D, 20/F., Kai Bo 22, 22 Wing Kin Road,
Kwai Chung, Hong Kong

PHONE +852 2832 9880

www.emauxgroup.com

 **YOUR PREMIER SUPPLIER**

Available from:

ALL SPECIFICATIONS ARE SUBJECT TO CHANGE WITHOUT NOTICE.
© 2021 EMAUX WATER TECHNOLOGY CO., LTD. ALL RIGHTS RESERVED.

www.emauxgroup.com