



Application

- It is suitable for boosting hot water powered by solar energy for sauna and bathing and solves insufficient water pressure in high-rise buildings.
- It can also supply water (less than 100°C) to two families.

Pump

- Cast iron pump body and support under special anti-rust treatment
- AISI 304 shaft
- Liquid temperature: 2°C - 100°C

Motor

- Insulation class: F
- Protection class: IP44

Identification Codes

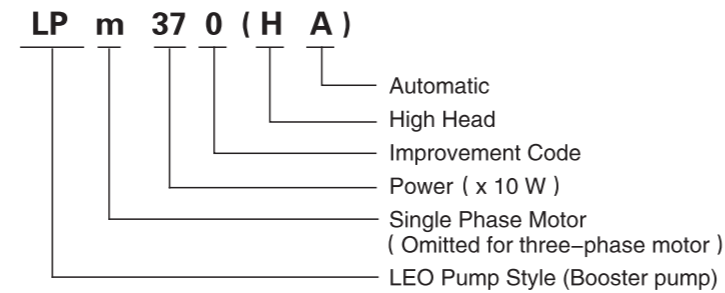

Technical Data

Model	Power kW	Qm ³ /h QL/min	H (m)															
			0	1.5	3	4.5	6	7.5	9	10.5	12	13.5	15	16.5	18	19.5		
LPm125	0.125		5.5	5	4.8	3.8	3	1.7	-	-	-	-	-	-	-	-	-	
LPm250	0.25		5.5	5.2	5.1	4.9	4.6	4.2	3.5	2.8	2	-	-	-	-	-	-	
LPm370	0.37		8	7.9	7.8	7.5	7.2	6.7	6.2	5.6	4.8	4	9.3	2.3	-	-	-	
LPm550	0.55		19	19	18.9	18	17	16	14.9	13.7	12.4	11.2	9.8	8.5	6.6	4	-	

Model	Power kW	Qm ³ /h QL/min	H (m)															
			0	0.6	1.2	1.8	2.4	3.0	3.6	4.2	4.8	5.4	6.0	6.6				
LPm370HA	0.37		21	20.6	18.5	16	13.4	10	5.5	-	-	-	-	-	-	-	-	
LPm750HA	0.75		30.8	30.7	30	29.5	28.3	26.3	24.4	22	19	16.2	13.2	9.4	-	-	-	

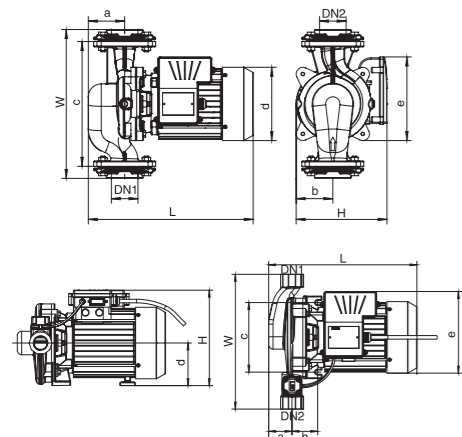

Dimension

Model	DN1	DN2	L (mm)	W (mm)	H (mm)	a (mm)	b (mm)	c (mm)	d (mm)	e (mm)
LPm125	1 1/2"	1 1/2"	275	260	186	47	74	210	Φ141	160
LPm250	2"	2"	301	313	190	71	78	260	Φ141	164
LPm370	2 1/2"	2 1/2"	367	334	195	77	84	280	Φ141	173
LPm550	2"	2"	369	344	210	81	87	280	Φ165	182
LPm370HA	1"	1"	295	270	209	43	60	124	Φ95	141
LPm750HA	1"	1"	341	310	220	54	59	160	Φ98	165

Hydraulic Performance Curves

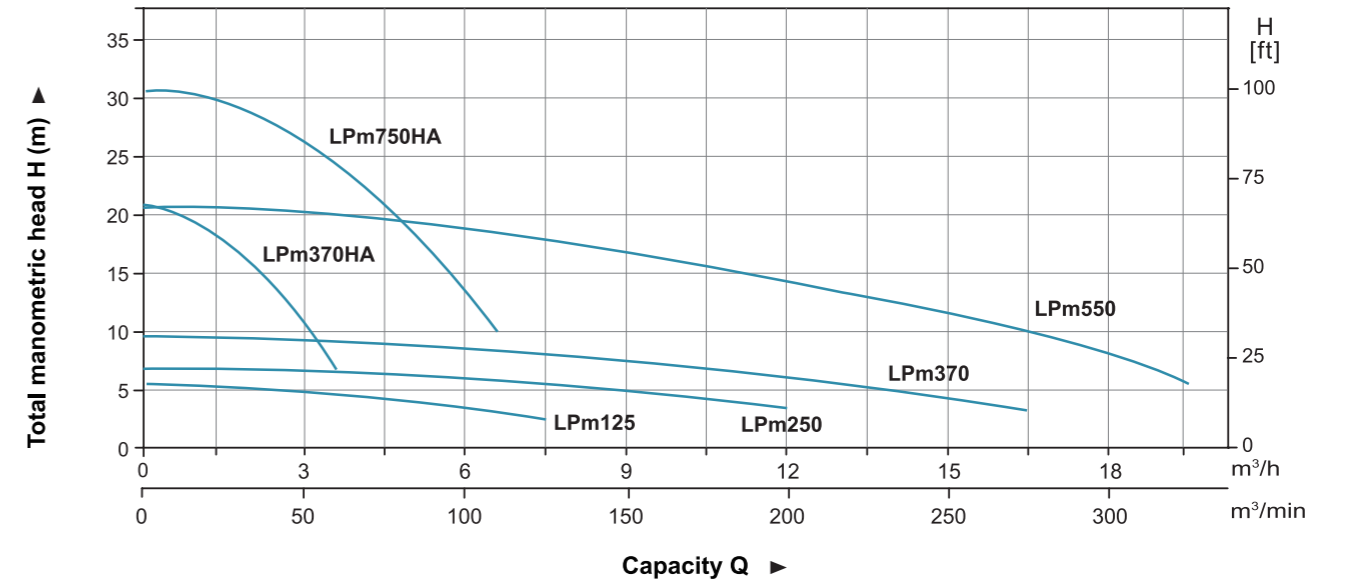

Materials Table

LPm125/LPm250/LPm370/LPm550

No.	Part	Material
1	Flange	HT200
2	Pump body	HT200
3	Flange gasket	
4	Impeller	PPO
5	Mechanical Seal	Carbon/Ceramic
6	O ring	
7	Support	HT200
8	Bearing	
9	Rotor	
10	Stator	
11	Terminal Box	ABS
12	Capacitor	
13	Terminal Box Cover	
14	Rear Cover	ZL102
15	Fan	PP
16	Fan cover	08F

LPm370HA/LPm750HA

No.	Part	Material
1	Pump body	HT200
2	Impeller	PPO
3	O ring	
4	Support	HT200
5	Bearing	
6	Rotor	
7	Mechanical Seal	Carbon/Ceramic
8	Control switch	
9	Stator	
10	Terminal Box	ABS
11	Capacitor	
12	Terminal Box Cover	
13	Rear Cover	ZL102
14	Fan	PP
15	Fan cover	08F

