



Application

- Suitable for transferring liquids of low viscosity, non-inflammable and non-explosive, not containing solid particles or fibers
- Water supply & drainage for high-rise buildings, filtration and transfer at waterworks, pressure boosting in main pipe
- Washing and cleaning systems, boiler feeding, cooling water circulation, water treatment systems, auxiliary system, support equipment
- Ultra-filtration systems, reverse-osmosis systems, distillation systems, separators, swimming pools
- Agricultural irrigation: sprinkler irrigation, drip-feed irrigation
- Food & beverage industry
- Fire-fighting system

Operating Conditions

- Low viscosity, non-inflammable and non-explosive liquids not containing solid particles or fibers. The liquids must not chemically attack the pump materials. When pumping liquids with a density or viscosity is higher than that of water, a motor with a higher output power rating shall be used.
- Liquid temperature: -20°C~+120°C
- Flow ranges: 0.7-240 m³/h
- Liquid pH value: 4 - 10
- Max. ambient temperature: +40°C
- Max. operation pressure: 33 bar
- Altitude: up to 1000 m

Motor

- IE 2 motor (IE 3 motor optional)
- Totally enclosed & fan-cooled
- Protection class: IP55
- Standard voltage: 50Hz 1 × 220V/3 × 380V

Identification Codes

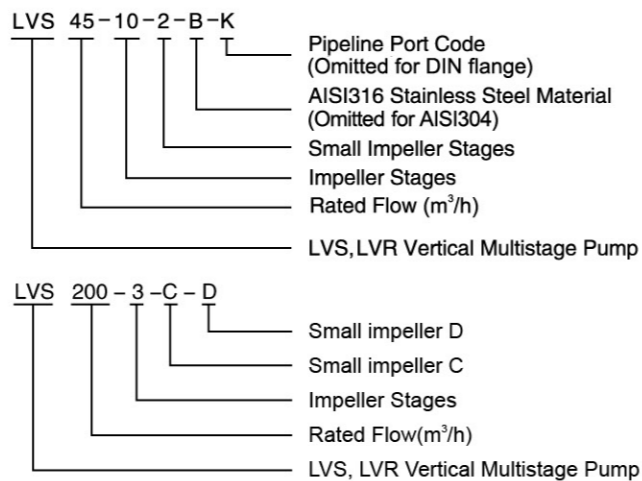

LVS: Stainless steel wetted parts
LVR: Cast iron base & pump cover

Identifications codes of flange structure

A: Oval flange; K: Clamp connector;
G: Threaded connector

Ambient Temperature

Max. ambient temperature: +40°C. Ambient temperature above 40°C or installation at altitude of more than 1000 meters above sea level require the use of an oversize motor. Because of low air density and poor cooling effects, the motor output power P₂ will be decreased. See the picture.

In such cases, it may be necessary to use a motor with a higher output power rating.

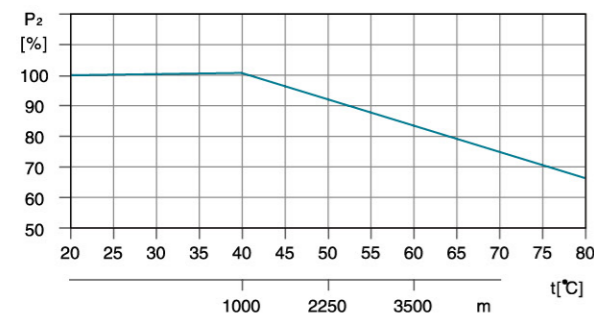

For example, when the pump is installed at altitude of more than 3500 meters above sea level, P₂ will be decreased to 88%. When the ambient temperature is 70°C, P₂ will be decreased to 78%.

Minimum Inlet Pressure-Npsh

Calculation of the inlet pressure "H" is recommended in these situations:

- The liquid temperature is high.
- The flow is significantly higher than the rated flow.
- Water is drawn from depths.
- Water is drawn through long pipes.
- Inlet conditions are poor.

To avoid cavitation, make sure that there is a minimum pressure on the suction side of the pump. The maximum suction lift "H" in meters head can be calculated as follows:

$$H = P_b \times 10.2 - NPSH - H_r - H_v - H_s$$

P_b = Barometric pressure in bar. (Barometric pressure can be set to 1 bar). In closed systems, P_b indicates the system pressure in bar.

NPSH = Net Positive Suction Head in meters head. (To be read from the NPSH curve at the highest flow the pump will be delivering.)

H_r = Friction loss in suction pipe in meters head. (At the highest flow the pump will be delivering.)

H_v = Vapor pressure in meters head. (To be read from the vapor pressure scale. "H_v" depends on the liquid temperature "tm")

H_s = Safety margin=minimum 0.5 meters head.

If the "H" calculated is positive, the pump can operate at a suction lift of maximum "H" meters head.

If the "H" calculated is negative, an inlet pressure of minimum "H" meters head is required.

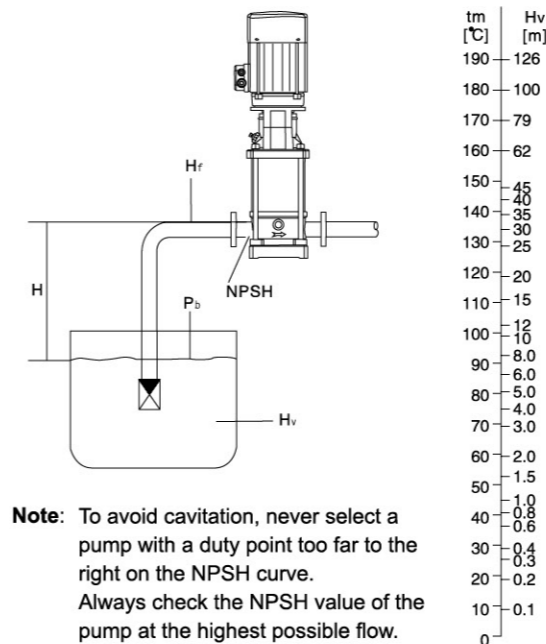

Note: To avoid cavitation, never select a pump with a duty point too far to the right on the NPSH curve. Always check the NPSH value of the pump at the highest possible flow.

Maximum Inlet Pressure

The following table shows the maximum permissible inlet pressure. However, the current inlet pressure + the pressure against a closed valve must always be lower than the Max. permissible operating pressure.

If the maximum permissible operating pressure is exceeded, the bearing in the motor may be damaged and the life of the shaft seal reduced.

Model	Max. Inlet Pressure [bar]
LVR(S) 1-2 - 1-36	10
LVR(S) 2-2	6
LVR(S) 2-3 - 2-12	10
LVR(S) 2-13 - 2-26	15
LVR(S) 3-2 - 3-29	10
LVR(S) 3-31 - 3-36	15
LVR(S) 4-2	6
LVR(S) 4-3 - 4-11	10
LVR(S) 4-12 - 4-22	15
LVR(S) 5-2 - 5-16	10
LVR(S) 5-18 - 5-29	15
LVR(S) 10-1 - 10-6	8
LVR(S) 10-7 - 10-22	10
LVR(S) 15-1 - 15-3	8
LVR(S) 15-4 - 15-17	10
LVR(S) 20-1 - 20-3	8
LVR(S) 20-4 - 20-17	10
LVR(S) 32-1-1 - 32-4	4
LVR(S) 32-5-2 - 32-10	10
LVR(S) 32-11 - 32-14	15
LVR(S) 45-1-1 - 45-2	4
LVR(S) 45-3-2 - 45-5	10
LVR(S) 45-6-2 - 45-13-2	15
LVR(S) 64-1-1 - 64-2-2	4
LVR(S) 64-2-1 - 64-4-2	10
LVR(S) 64-4-1 - 64-8-1	15
LVR(S) 90-1-1 - 90-1	4
LVR(S) 90-2-2 - 90-3-2	10
LVR(S) 90-3 - 90-6	15
LVR(S) 120-1 - 120-2-1	10
LVR(S) 120-2 - 120-5-1	15
LVR(S) 120-5 - 120-7	20
LVR(S) 150-1-1 - 150-2-2	10
LVR(S) 150-2-1 - 150-4-1	15
LVR(S) 150-4 - 150-6	20
LVR(S) 200-1-D	10
LVR(S) 200-1-C - 200-2-2C	15
LVR(S) 200-2-C - 200-4	20

Model	LVR Max. Inlet Pressure [bar]		LVS Max. Inlet Pressure [bar]
	Oval Flange	DIN Flange	
LVR(S) 1	16	25	25
LVR(S) 2	16	25	25
LVR(S) 3	16	25	25
LVR(S) 4	16	25	25
LVR(S) 5	16	25	25
LVR(S) 10		25	25
LVR(S) 15		25	25
LVR(S) 20		25	25
LVR(S) 32-1-1 - 32-7	16		16
LVR(S) 32-8-2 - 32-14	30		30
LVR(S) 45-1-1 - 45-5	16		16
LVR(S) 45-6-2 - 45-11	30		30
LVR(S) 45-12-2 - 45-13-2	33		33
LVR(S) 64-1-1 - 64-5	16		16
LVR(S) 64-6-2 - 64-8-1	30		30
LVR(S) 90-1-1 - 90-4	16		16
LVR(S) 90-5-2 - 90-6	30		30
LVR(S) 120-1 - 120-7	20		20
LVR(S) 150-1-1 - 150-6	20		20
LVR(S) 200-1-D - 200-4	20		20

How to Read The Curve Charts

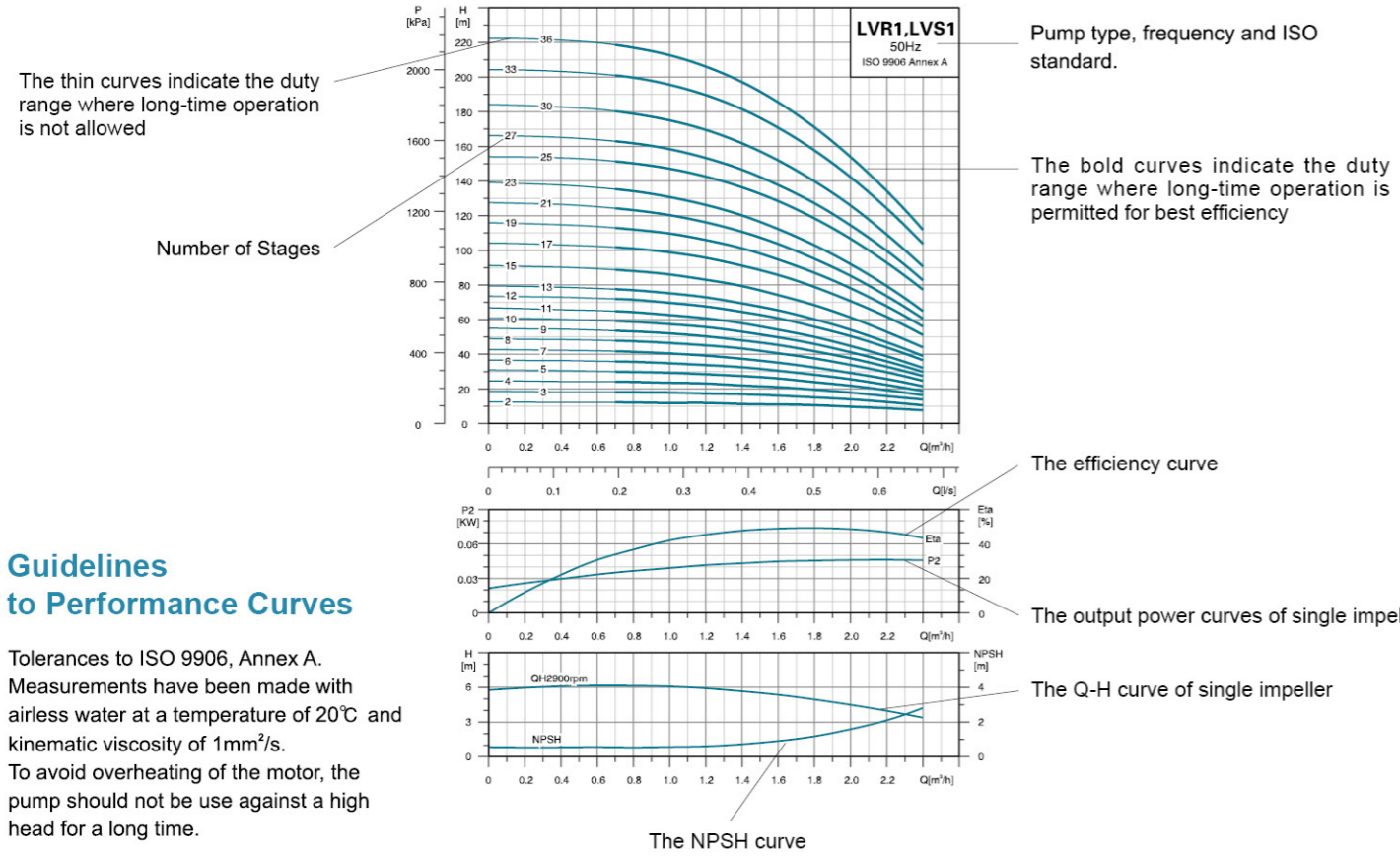

Guidelines to Performance Curves

Tolerances to ISO 9906, Annex A. Measurements have been made with airless water at a temperature of 20°C and kinematic viscosity of 1mm²/s. To avoid overheating of the motor, the pump should not be use against a high head for a long time.

Minimum Flow Rate

Due to the risk of overheating, the pump should not be used at a flow below the minimum flow rate. The curve below shows the minimum flow rate as a percentage of the nominal flow rate in relation to the liquid temperature.

Air cooling apparatus

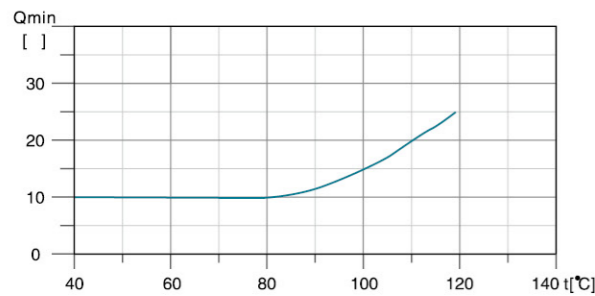

Note: The outlet valve must be opened when the pump is in operation.

Terminal Box Positions
(Note: set to position 1 before delivery)

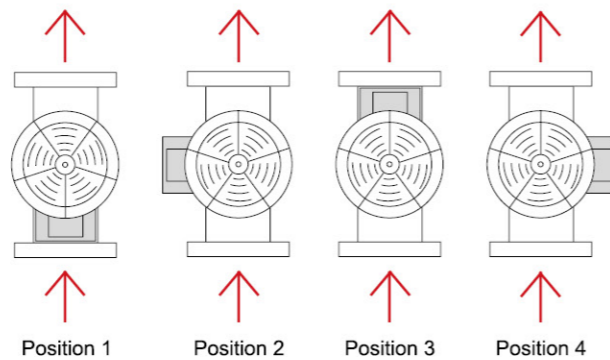

Product Range

MODEL	LVR(S)1	LVR(S)2	LVR(S)3	LVR(S)4	LVR(S)5	LVR(S)10	LVR(S)15	LVR(S)20	LVR(S)32	LVR(S)45	LVR(S)64	LVR(S)90	LVR(S)120	LVR(S)150	LVR(S)200
DESCRIPTION															
Rated flow [m ³ /h]	1	2	3	4	5	10	15	20	32	45	64	90	120	150	200
Flow range [m ³ /h]	0.7-2.4	1.0-3.5	1.2-4.5	1.5-8	2.5-8.5	5-13	8-23	10.5-29	15-40	22-58	30-85	45-120	60-150	80-180	100-240
Max. pressure [bar]	22	23	24	21	24	22	23	25	28	33	22	20	16	16	16
Motor power [kW]	0.37-2.2	0.37-3	0.37-3	0.37-4	0.37-4	1.1-7.5	1.1-15	1.1-18.5	1.5-30	3-45	4-45	5.5-45	11-75	11-75	18.5-110
Temperature Range [°C]	-20°C~+120°C (Note: Both the Max. permissible pressure and liquid temperature range refer to the pump capacity.)														
Max. pump efficiency [%]	45	46	55	59	60	65	70	72	78	79	80	81	74	73	79
Pipe connection-LVR															
Oval flange	G1	G1	G1	G1 1/4	G1 1/4	-	-	-	-	-	-	-	-	-	-
DIN flange	DN25	DN25	DN25	DN32	DN32	DN40	DN50	DN50	DN65	DN80	DN100	DN100	DN125	DN125	DN150
Pipe connection-LVS															
Oval flange	-	-	-	-	-	-	-	-	-	-	-	-	-	-	-
DIN flange	DN32	DN32	DN32	DN32	DN32	DN40	DN50	DN50	DN65	DN80	DN100	DN100	DN125	DN125	DN150
Clamp connector	φ 42	φ 42	φ 42	φ 42	φ 42	-	-	-	-	-	-	-	-	-	-
Threaded connector	R ₂ 1 1/4	R ₂ 1 1/4	R ₂ 1 1/4	R ₂ 1 1/4	R ₂ 1 1/4	-	-	-	-	-	-	-	-	-	-

Scope of Performance-LVR,LVS

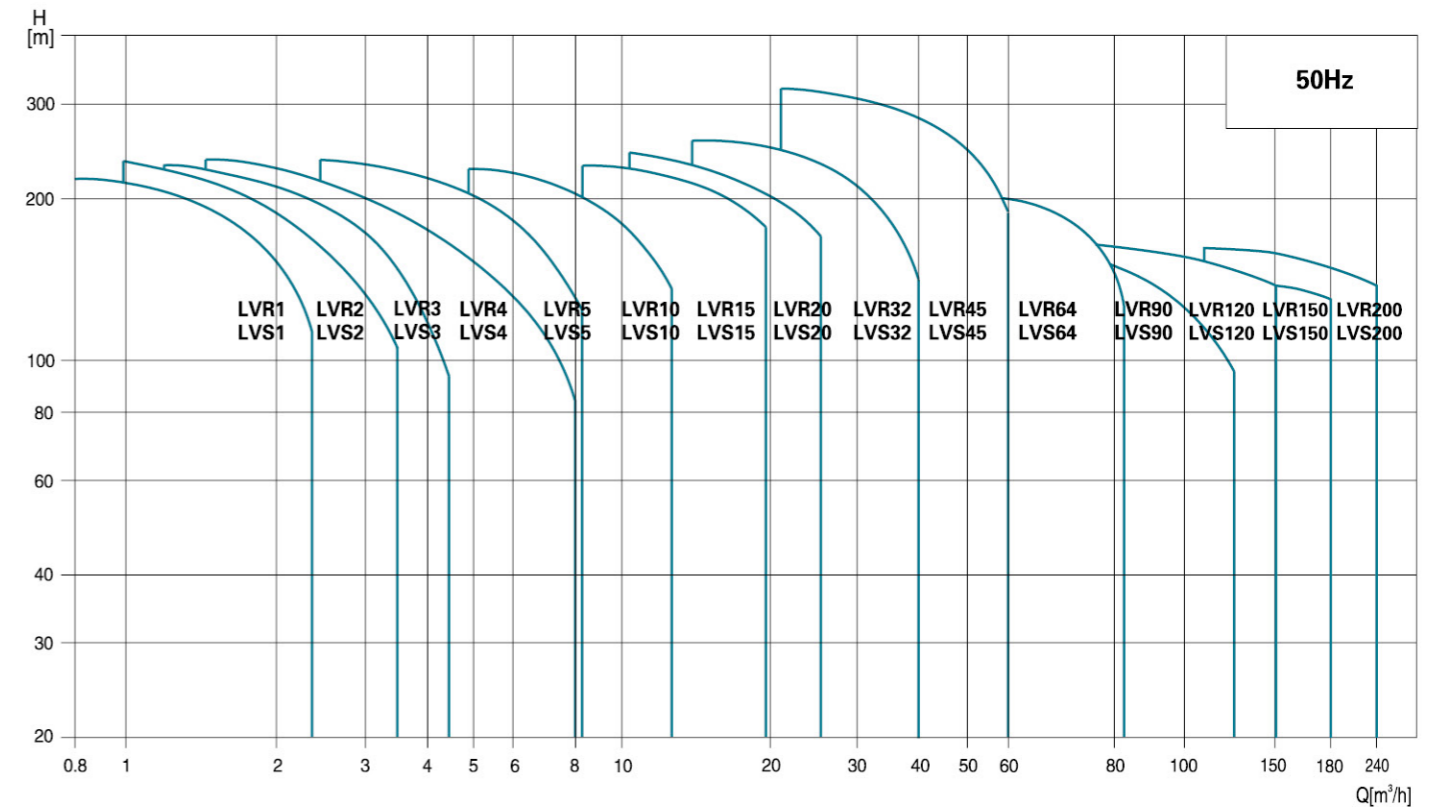

Cross Section

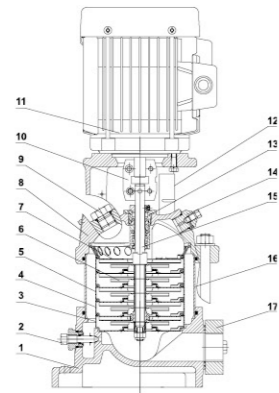

MODEL: LVR1 (2,3,4,5)

Part	Material
1 Base	HT200
2 Drainage plug assembly	AISI304
3 Primary diffuser	AISI304
4 Diffuser with bearing	AISI304
5 Medium diffuser	AISI304
6 Impeller	AISI304
7 Final volute	AISI304
8 Motor base	HT200
9 Filling plug	AISI304
10 Coupling	Iron based powder metallurgy
11 Motor	
12 Guarding plate	AISI304
13 Cartridge seal	
14 Vent plug assembly	AISI304
15 Pump shaft	AISI316
16 Pump barrel	AISI304
17 Oval flange	HT200

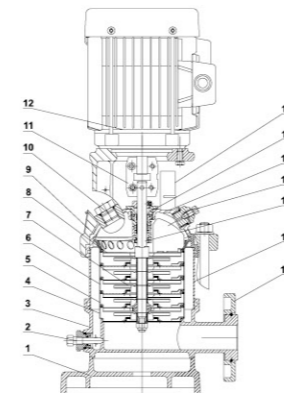

MODEL: LVS1 (2,3,4,5)

Part	Material	Optional Material
1 Base plate	HT200	
2 Drainage plug assembly	AISI304	AISI316
3 Chasis	ZG304	ZG316
4 Primary diffuser	AISI304	AISI316
5 Diffuser with bearing	AISI304	AISI316
6 Medium diffuser	AISI304	AISI316
7 Impeller	AISI304	AISI316
8 Final volute	AISI304	AISI316
9 Motor base	HT200	
10 Filling plug	AISI304	AISI316
11 Coupling	Iron based powder metallurgy	
12 Motor		
13 Guarding plate	AISI304	
14 Cartridge seal		
15 Pump cover	ZG304	ZG316
16 Vent plug assembly	AISI304	AISI316
17 Pump shaft	AISI316	
18 Pump barrel	AISI304	AISI316
19 Flange	ZG35	

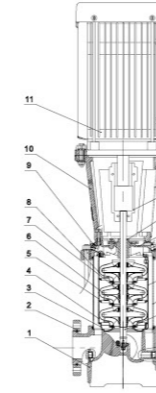

MODEL: LVR32 (45,64,90)

Part	Material
1 Base plate	HT200
2 Flange	ZG35
3 Primary diffuser	AISI304
4 Medium diffuser	AISI304
5 Diffuser with bearing	AISI304
6 Impeller	AISI304
7 Shaft sleeve assembly	
8 Final diffuser	AISI304
9 Vent plug assembly	AISI304
10 Motor base	HT200
11 Motor	
12 Guarding plate	AISI304
13 Coupling	QT400
14 Cartridge seal	
15 HT200 Pump head	HT200
16 Filling plug	AISI304
17 Tension plate	AISI304
18 Pump barrel	AISI304
19 Pump shaft	AISI304

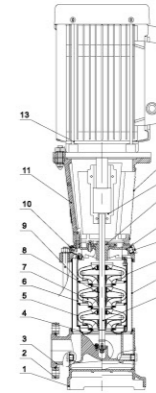

MODEL: LVS32 (45,64,90)

Part	Material	Optional Material
1 Base plate	HT200	
2 Flange	ZG35	
3 Chasis	ZG304	ZG316
4 Primary diffuser	AISI304	AISI316
5 Medium diffuser	AISI304	AISI316
6 Diffuser with bearing	AISI304	AISI316
7 Impeller	AISI304	AISI316
8 Shaft sleeve assembly		
9 Final diffuser	AISI304	AISI316
10 Vent plug assembly	AISI304	AISI316
11 Motor base	HT200	
12 Motor		
13 Guarding plate	AISI304	
14 Coupling	QT400	
15 Cartridge seal		
16 Pump head	ZG304	ZG316
17 Filling plug	AISI304	AISI316
18 Tension plate	AISI304	AISI316
19 Pump barrel	AISI304	AISI316
20 Pump shaft	AISI304	AISI316

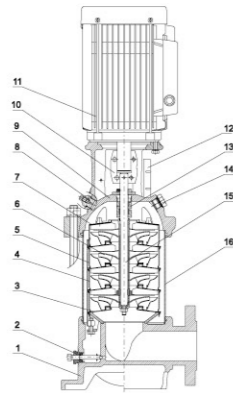

MODEL: LVR10 (15,20)

Part	Material
1 Base	HT200
2 Drainage plug assembly	AISI304
3 Primary diffuser	AISI304
4 Diffuser with bearing	AISI304
5 Medium diffuser	AISI304
6 Impeller	AISI304
7 Final volute	AISI304
8 Filling plug	AISI304
9 Motor base	HT200
10 Coupling	Iron based powder metallurgy
11 Motor	
12 Guarding plate	AISI304
13 Cartridge seal	
14 Vent plug assembly	AISI304
15 Pump shaft	AISI316
16 Pump barrel	AISI304

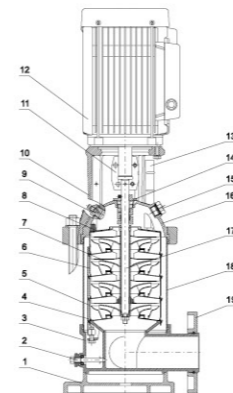

MODEL: LVS10 (15,20)

Part	Material	Optional Material
1 Base plate	HT200	
2 Drainage plug assembly	AISI304	AISI316
3 Chasis	ZG304	ZG316
4 Primary diffuser	AISI304	AISI316
5 Diffuser with bearing	AISI304	AISI316
6 Medium diffuser	AISI304	AISI316
7 Impeller	AISI304	AISI316
8 Final volute	AISI304	AISI316
9 Filling plug	AISI304	AISI316
10 Motor base	HT200	
11 Coupling	Iron based powder metallurgy	
12 Motor		
13 Guarding plate	AISI304	
14 Cartridge seal		
15 Vent plug assembly	AISI304	AISI316
16 Pump cover	ZG304	AISI316
17 Pump shaft	AISI316	
18 Pump barrel	AISI304	AISI316
19 Flange	ZG35	

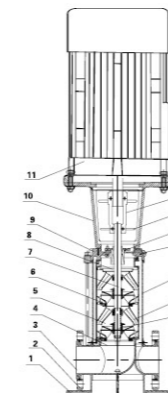

MODEL: LVR120 (150,200)

Part	Material
1 Base plate	HT200
2 Flange	ZG35
3 Base	HT200
4 Primary diffuser	AISI304
5 Medium diffuser	AISI304
6 Diffuser with bearing	AISI304
7 Impeller	AISI304
8 Final diffuser	AISI304
9 Pump head	HT200
10 Motor base	HT200
11 Motor	
12 Coupling	QT400
13 Guarding plate	AISI304
14 Cartridge seal	
15 Filling plug	AISI304
16 Tension plate	AISI304
17 Pump barrel	AISI304
18 Pump shaft	AISI304

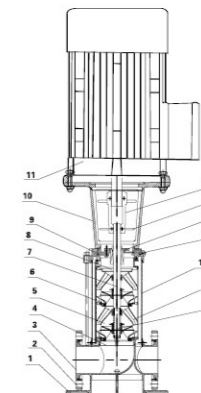

MODEL: LVS120 (150,200)

Part	Material	Optional Material
1 Base plate	HT200	
2 Flange	ZG35	
3 Chasis	ZG304	ZG316
4 Primary diffuser	AISI304	AISI316
5 Medium diffuser	AISI304	AISI316
6 Diffuser with bearing	AISI304	AISI316
7 Impeller	AISI304	AISI316
8 Final diffuser	AISI304	AISI316
9 Pump head	ZG304	ZG316
10 Motor base	HT200	
11 Motor		
12 Coupling	QT400	
13 Guarding plate	AISI304	
14 Cartridge seal		
15 Filling plug	AISI304	AISI316
16 Tension plate	AISI304	AISI316
17 Pump barrel	AISI304	AISI316
18 Pump shaft	AISI304	AISI316

Hydraulic Performance Curves

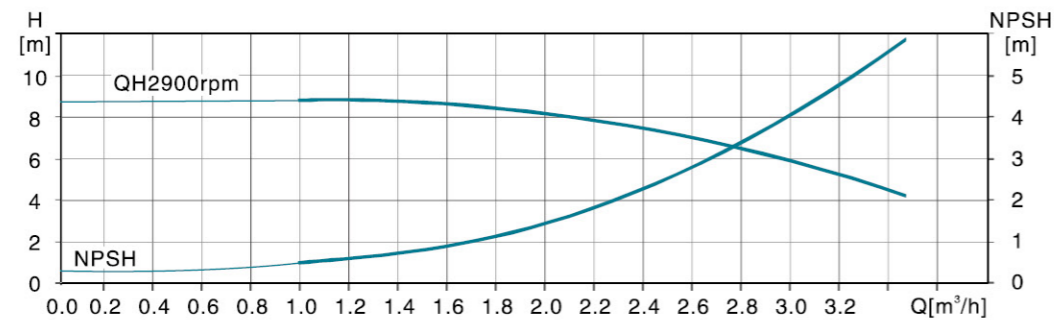
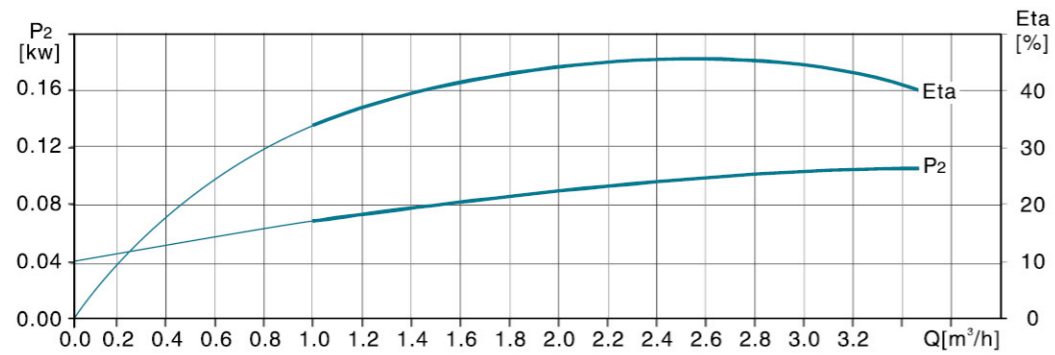
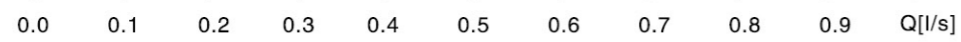
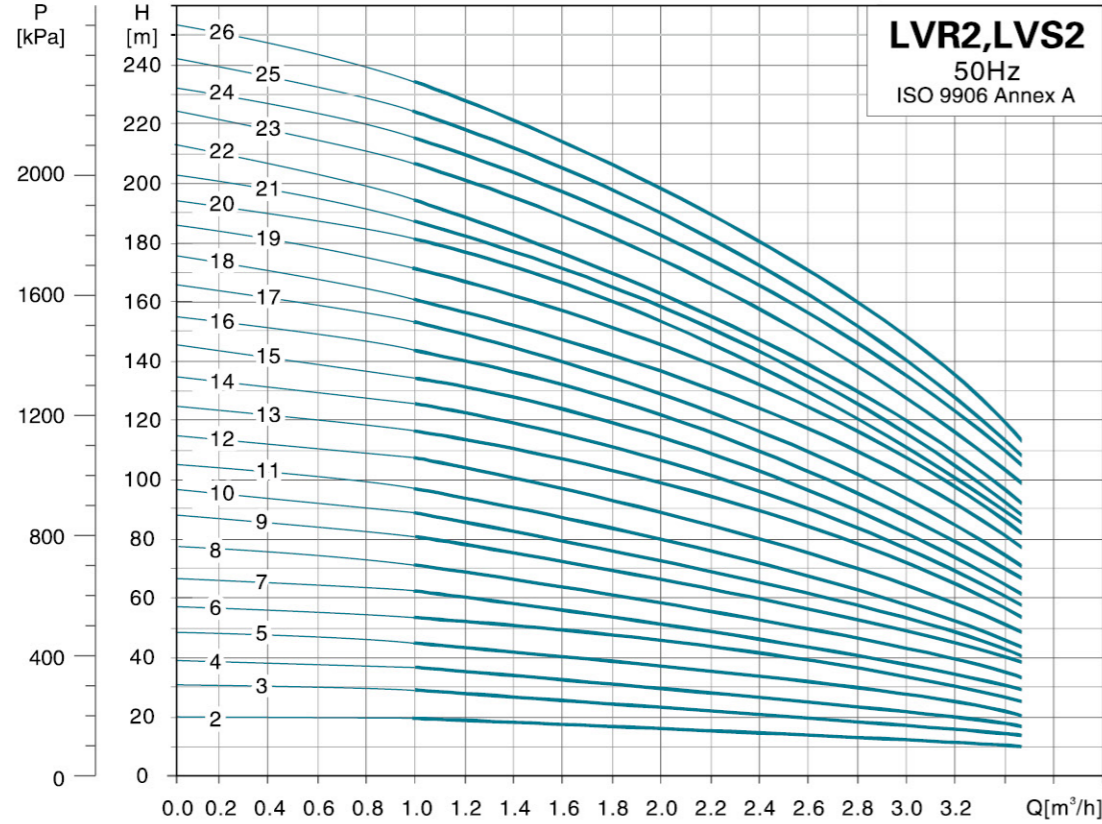

Dimension Drawing

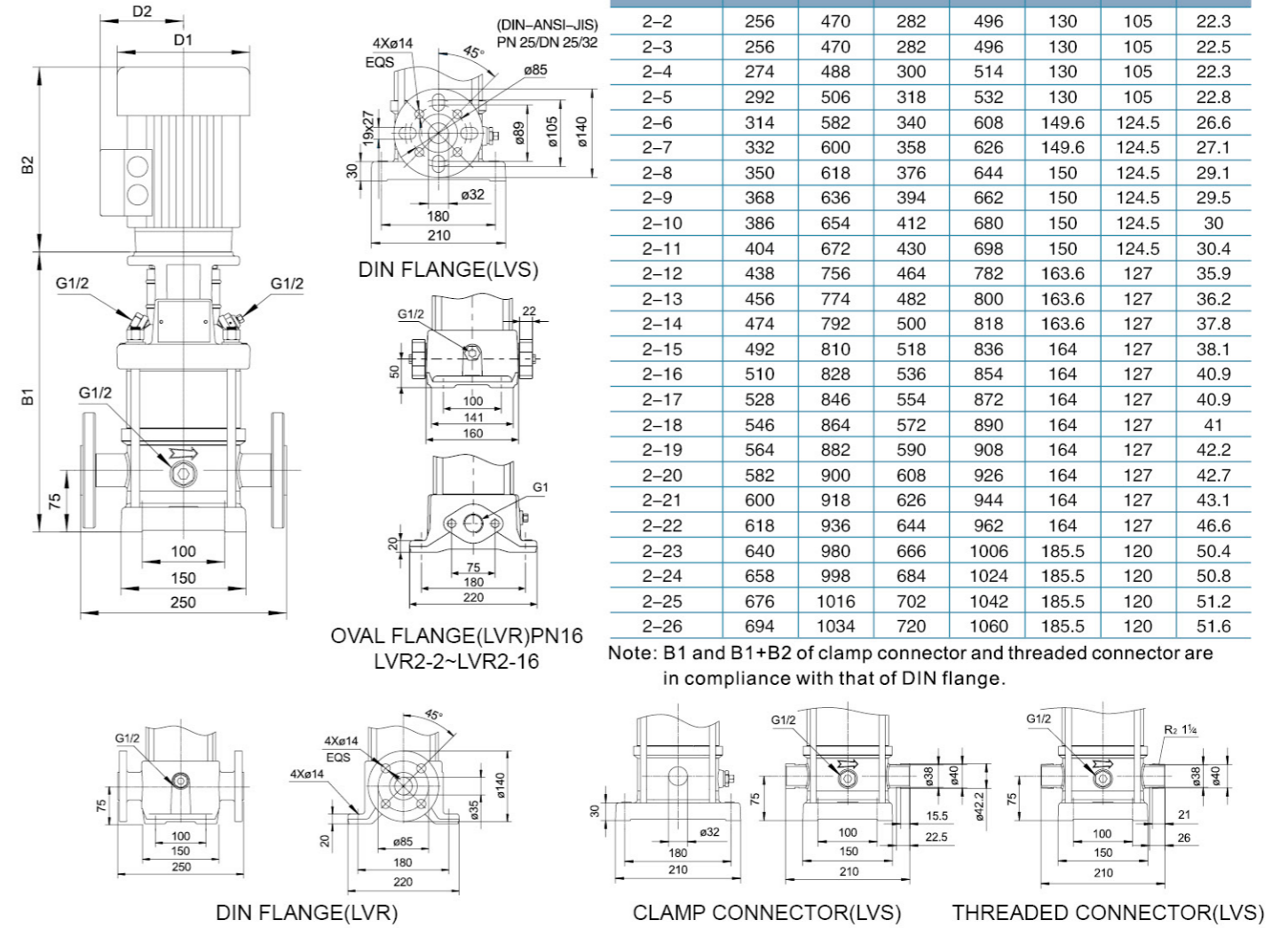

MODEL	OVAL FLANGE (LVR)		DIN FLANGE (LVR, LVS)		D1	D2	N.W. (kgs)
	B1	B1+B2	B1	B1+B2			
2-2	256	470	282	496	130	105	22.3
2-3	256	470	282	496	130	105	22.5
2-4	274	488	300	514	130	105	22.3
2-5	292	506	318	532	130	105	22.8
2-6	314	582	340	608	149.6	124.5	26.6
2-7	332	600	358	626	149.6	124.5	27.1
2-8	350	618	376	644	150	124.5	29.1
2-9	368	636	394	662	150	124.5	29.5
2-10	386	654	412	680	150	124.5	30
2-11	404	672	430	698	150	124.5	30.4
2-12	438	756	464	782	163.6	127	35.9
2-13	456	774	482	800	163.6	127	36.2
2-14	474	792	500	818	163.6	127	37.8
2-15	492	810	518	836	164	127	38.1
2-16	510	828	536	854	164	127	40.9
2-17	528	846	554	872	164	127	40.9
2-18	546	864	572	890	164	127	41
2-19	564	882	590	908	164	127	42.2
2-20	582	900	608	926	164	127	42.7
2-21	600	918	626	944	164	127	43.1
2-22	618	936	644	962	164	127	46.6
2-23	640	980	666	1006	185.5	120	50.4
2-24	658	998	684	1024	185.5	120	50.8
2-25	676	1016	702	1042	185.5	120	51.2
2-26	694	1034	720	1060	185.5	120	51.6

Note: B1 and B1+B2 of clamp connector and threaded connector are in compliance with that of DIN flange.

MODEL	POWER[kW]	Q[m³/h]	1.0	1.2	1.6	2.0	2.5	2.8	3.2	3.5
LVR(S)2-2	0.37	18	17	16	15.5	13.5	12	10	8	
LVR(S)2-3	0.37	27	26	24	22.5	19.5	18	15	12	
LVR(S)2-4	0.55	36	35	33	30.5	27	24	17	16	
LVR(S)2-5	0.55	45	43	40	37	32.5	30	24	20	
LVR(S)2-6	0.75	53	52	50	45.5	40	36	30	24	
LVR(S)2-7	0.75	63	61	57	52	45.5	41	35	28	
LVR(S)2-8	1.1	71	69	65	59	51	47	40	33	
LVR(S)2-9	1.1	80	78	73	68.5	60	54	45	37	
LVR(S)2-10	1.1	89	86	81	74	65	59	49	40	
LVR(S)2-11	1.1	98	95	89	82	71.5	64	54	44	
LVR(S)2-12	1.5	107	103	97	90	78	71	59	47	
LVR(S)2-13	1.5	116	114	106	98	86.5	78	65	52	
LVR(S)2-14	1.5	125	122	114	105	92	84	69	57	
LVR(S)2-15	1.5	134	130	123	112	98	90	73	60	
LVR(S)2-16	2.2	143	139	131	120	104	96	79	66	
LVR(S)2-17	2.2	152	148	139	128	111	102	85	70	
LVR(S)2-18	2.2	161	157	148	136	122	108	91	76	
LVR(S)2-19	2.2	170	165	156	143	128	113	95	81	
LVR(S)2-20	2.2	179	174	164	150	134	119	100	85	
LVR(S)2-21	2.2	188	183	172	157	140	124	105	88	
LVR(S)2-22	2.2	197	192	180	165	145	130	110	90	
LVR(S)2-23	3.0	205	201	188	173	153	137	105	97	
LVR(S)2-24	3.0	214	210	197	181	160	144	120	105	
LVR(S)2-25	3.0	223	219	205	189	168	151	125	107	
LVR(S)2-26	3.0	232	228	214	198	176	158	130	110	

Hydraulic Performance Curves

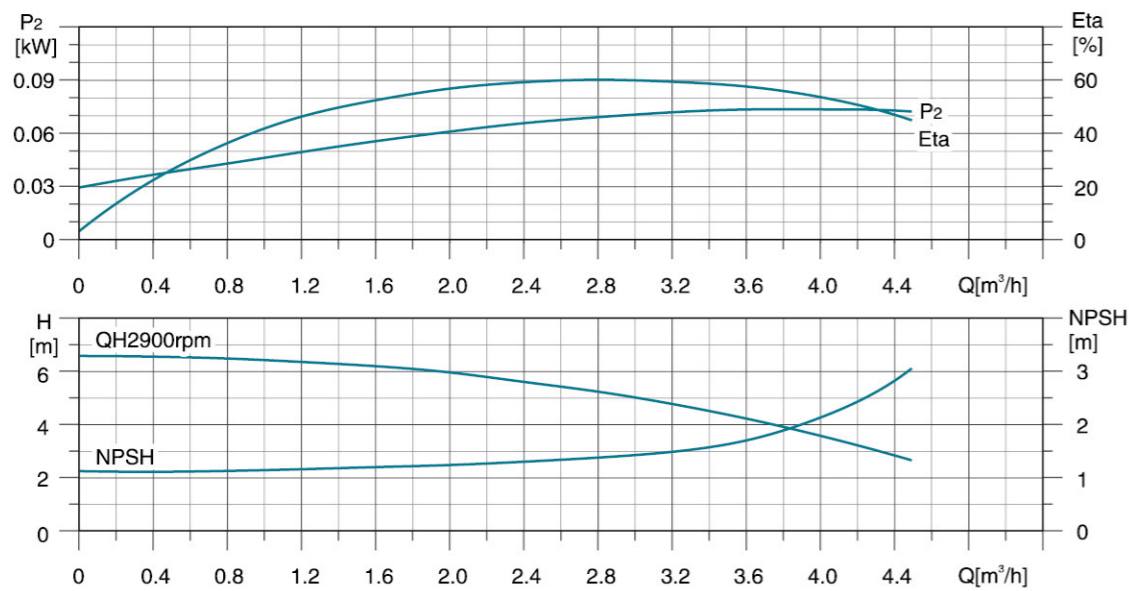
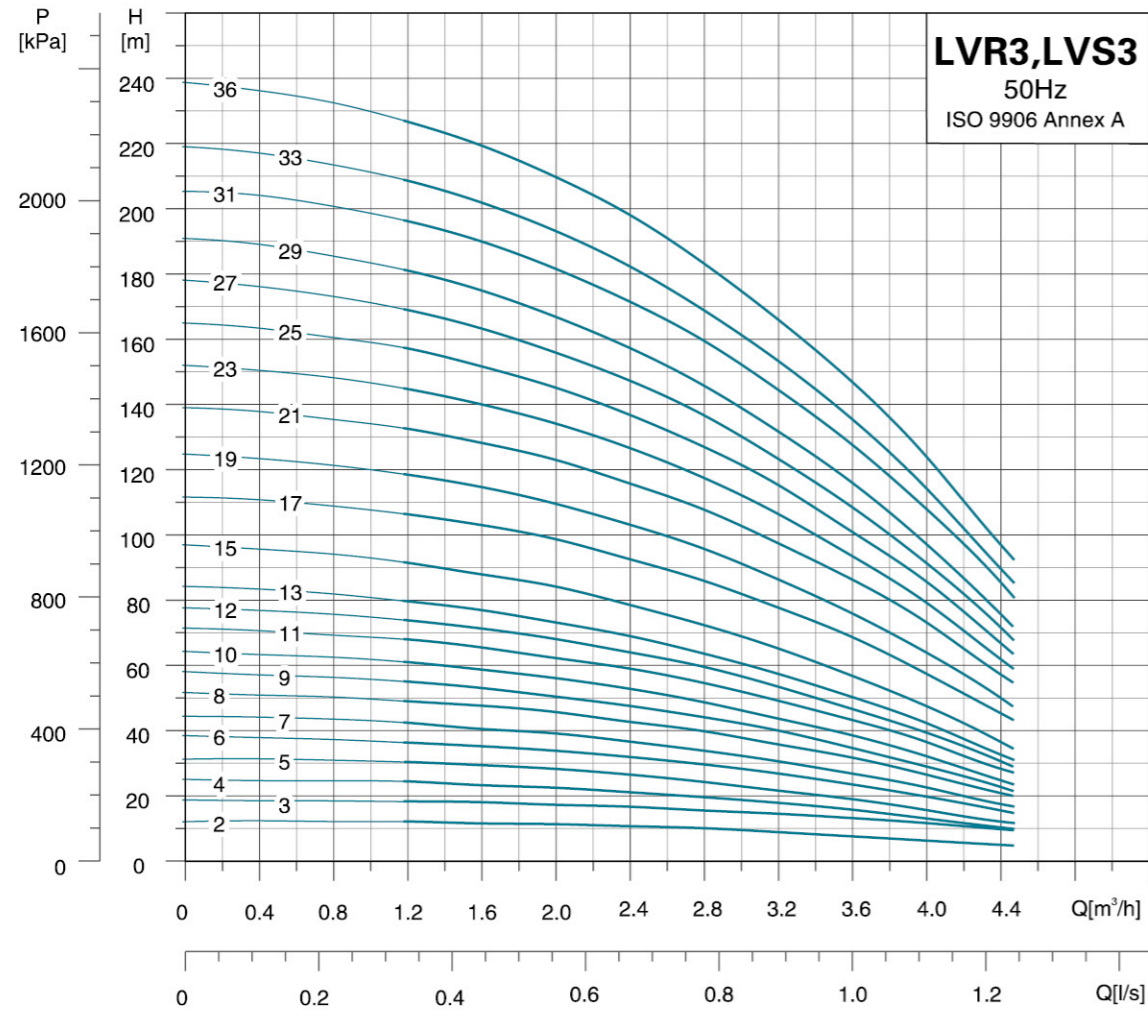

Dimension Drawing

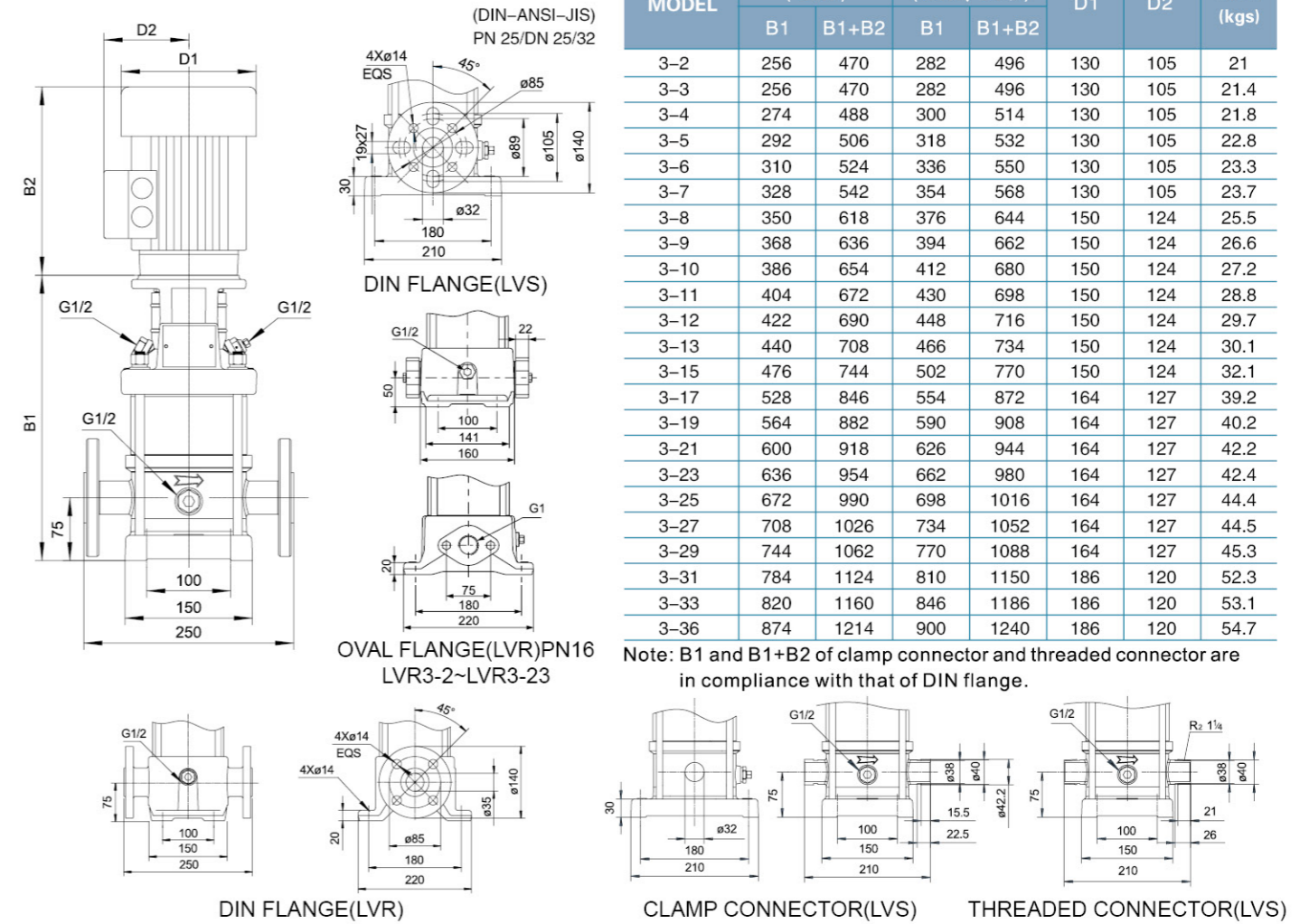

MODEL	OVAL FLANGE (LVR)		DIN FLANGE (LVR, LVS)		D1	D2	N.W. (kgs)
	B1	B1+B2	B1	B1+B2			
3-2	256	470	282	496	130	105	21
3-3	256	470	282	496	130	105	21.4
3-4	274	488	300	514	130	105	21.8
3-5	292	506	318	532	130	105	22.8
3-6	310	524	336	550	130	105	23.3
3-7	328	542	354	568	130	105	23.7
3-8	350	618	376	644	150	124	25.5
3-9	368	636	394	662	150	124	26.6
3-10	386	654	412	680	150	124	27.2
3-11	404	672	430	698	150	124	28.8
3-12	422	690	448	716	150	124	29.7
3-13	440	708	466	734	150	124	30.1
3-15	476	744	502	770	150	124	32.1
3-17	528	846	554	872	164	127	39.2
3-19	564	882	590	908	164	127	40.2
3-21	600	918	626	944	164	127	42.2
3-23	636	954	662	980	164	127	42.4
3-25	672	990	698	1016	164	127	44.4
3-27	708	1026	734	1052	164	127	44.5
3-29	744	1062	770	1088	164	127	45.3
3-31	784	1124	810	1150	186	120	52.3
3-33	820	1160	846	1186	186	120	53.1
3-36	874	1214	900	1240	186	120	54.7

Note: B1 and B1+B2 of clamp connector and threaded connector are in compliance with that of DIN flange.

MODEL	POWER[kW]	Q[m³/h]	1.2	1.6	2.0	2.4	2.8	3	3.6	4.0	4.5
LVR(S)3-2	0.37		13	12	12	11	11	10	8	7.5	4
LVR(S)3-3	0.37		19	19	18	17	16	15	14	12	8
LVR(S)3-4	0.37		25	24	23	22	20	19	17	14	9
LVR(S)3-5	0.37		31	31	29	27	25	24	20	17	11
LVR(S)3-6	0.55		37	36	35	33	30	28	24	21	14
LVR(S)3-7	0.55		43	40	40	37	35	32	28	24	16
LVR(S)3-8	0.75		51	48	47	44	41	38	33	28	19
LVR(S)3-9	0.75		56	54	51	48	45	42	36	30	21
LVR(S)3-10	0.75		62	60	57	54	50	46	40	33	23
LVR(S)3-11	1.1		69	66	63	60	56	51	44	38	26
LVR(S)3-12	1.1		75	72	69	65	61	56	48	41	28
LVR(S)3-13	1.1		80	78	74	70	65	60	51	44	30
LVR(S)3-15	1.1		92	89	85	80	73	68	58	49	34
LVR(S)3-17	1.5		107	104	100	94	87	78	70	59	42
LVR(S)3-19	1.5		119	116	111	104	97	87	77	65	47
LVR(S)3-21	2.2		133	129	124	117	109	97	88	75	54
LVR(S)3-23	2.2		146	141	135	128	119	105	95	81	59
LVR(S)3-25	2.2		158	153	146	138	128	115	102	87	64
LVR(S)3-27	2.2		170	164	157	148	138	124	110	93	67
LVR(S)3-29	2.2		182	176	168	159	147	133	118	100	72
LVR(S)3-31	3.0		197	191	183	173	161	142	128	110	80
LVR(S)3-33	3.0		210	203	194	194	170	152	137	116	84
LVR(S)3-36	3.0		228	221	211	200	185	165	149	126	91

Hydraulic Performance Curves

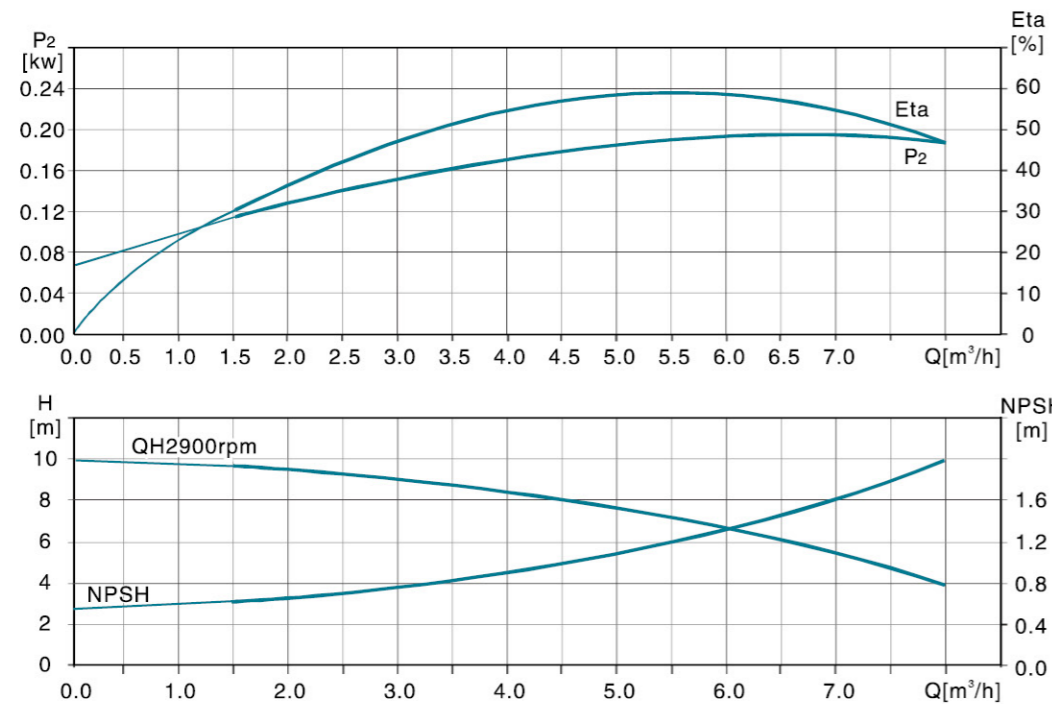
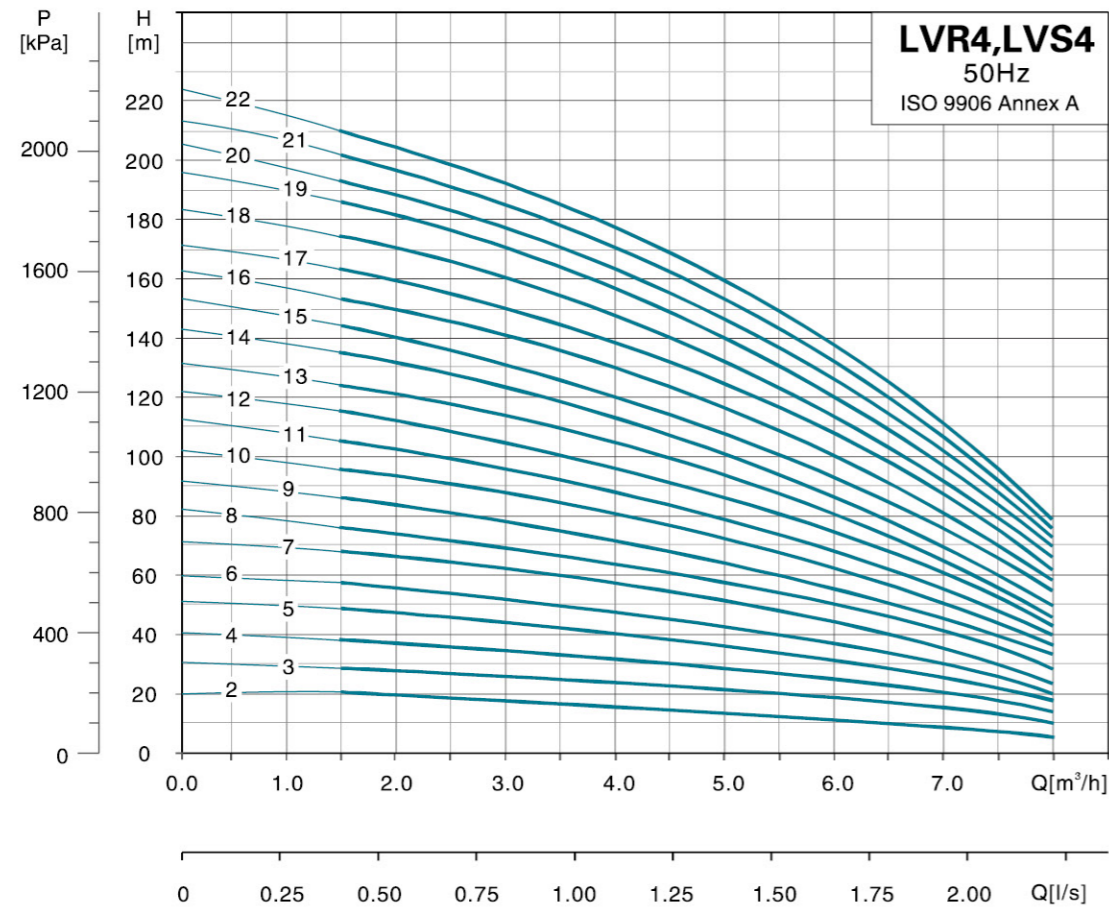

Dimension Drawing

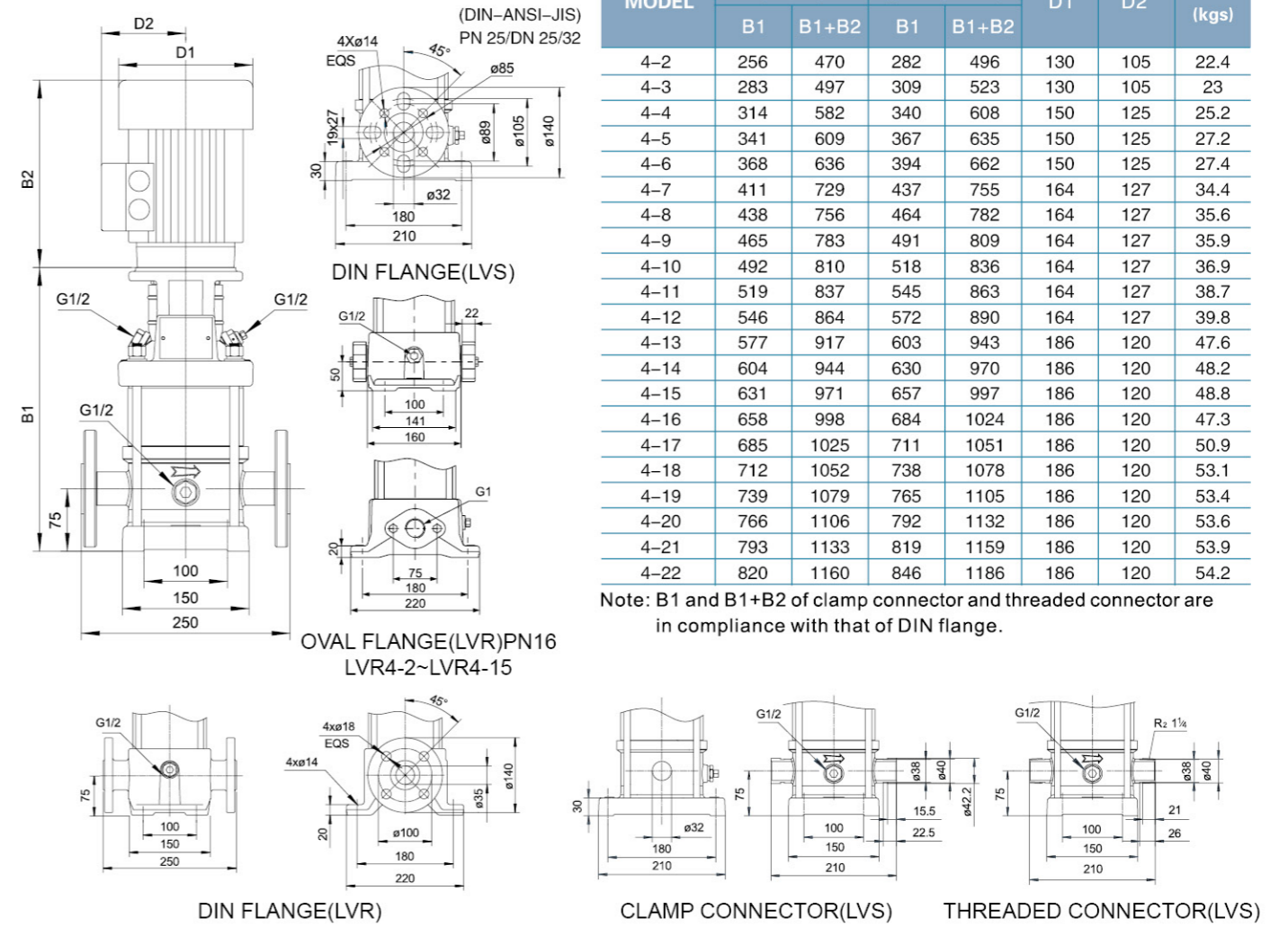

MODEL	OVAL FLANGE (LVR)		DIN FLANGE (LVR, LVS)		D1	D2	N.W. (kgs)
	B1	B1+B2	B1	B1+B2			
4-2	256	470	282	496	130	105	22.4
4-3	283	497	309	523	130	105	23
4-4	314	582	340	608	150	125	25.2
4-5	341	609	367	635	150	125	27.2
4-6	368	636	394	662	150	125	27.4
4-7	411	729	437	755	164	127	34.4
4-8	438	756	464	782	164	127	35.6
4-9	465	783	491	809	164	127	35.9
4-10	492	810	518	836	164	127	36.9
4-11	519	837	545	863	164	127	38.7
4-12	546	864	572	890	164	127	39.8
4-13	577	917	603	943	186	120	47.6
4-14	604	944	630	970	186	120	48.2
4-15	631	971	657	997	186	120	48.8
4-16	658	998	684	1024	186	120	47.3
4-17	685	1025	711	1051	186	120	50.9
4-18	712	1052	738	1078	186	120	53.1
4-19	739	1079	765	1105	186	120	53.4
4-20	766	1106	792	1132	186	120	53.6
4-21	793	1133	819	1159	186	120	53.9
4-22	820	1160	846	1186	186	120	54.2

Note: B1 and B1+B2 of clamp connector and threaded connector are in compliance with that of DIN flange.

MODEL	POWER[kW]	Q[m³/h]	1.5	2.0	3.0	4.0	5.0	6.0	7.0	8.0
LVR(S)4-2	0.37		19	18	17	14.5	13	10.5	8	6
LVR(S)4-3	0.55		28	27	26	23.5	20	18	14	10
LVR(S)4-4	0.75		38	36	34	31.5	27	24.5	18	13
LVR(S)4-5	1.1		47	45	43	40.5	34	31.5	23	17
LVR(S)4-6	1.1		56	54	52	47.5	41	36	28	20
LVR(S)4-7	1.5		66	63	61	57	48	44.5	34	24
LVR(S)4-8	1.5		74	72	70	64	55	49.5	38	27
LVR(S)4-9	2.2		86	81	78	72	63	56	44	32
LVR(S)4-10	2.2		96	90	87	81	71	64	50	34
LVR(S)4-11	2.2		105	99	95	88	78	69	53	39
LVR(S)4-12	2.2	H(m)	114	108	104	96	85	75	57	41
LVR(S)4-13	3.0		123	117	113	103	93	83	63	45
LVR(S)4-14	3.0		136	126	122	114	101	90	69	48
LVR(S)4-15	3.0		142	135	131	120	108	96	73	52
LVR(S)4-16	3.0		152	144	140	129	115	102	78	55
LVR(S)4-17	4.0		163	153	149	137	122	108	83	62
LVR(S)4-18	4.0		175	162	158	145	129	115	89	65
LVR(S)4-19	4.0		183	171	168	155	137	123	95	67
LVR(S)4-20	4.0		192	180	176	161	144	128	99	72
LVR(S)4-21	4.0		203	200	184	169	152	134	103	75
LVR(S)4-22	4.0		211	210	192	177	160	139	108	79

Hydraulic Performance Curves

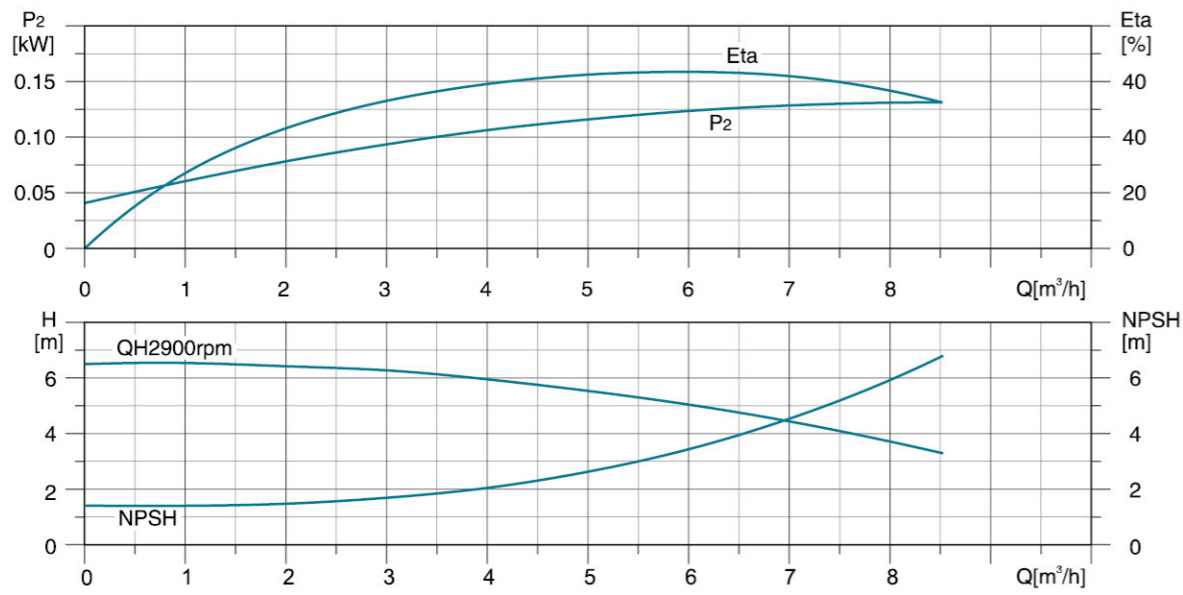
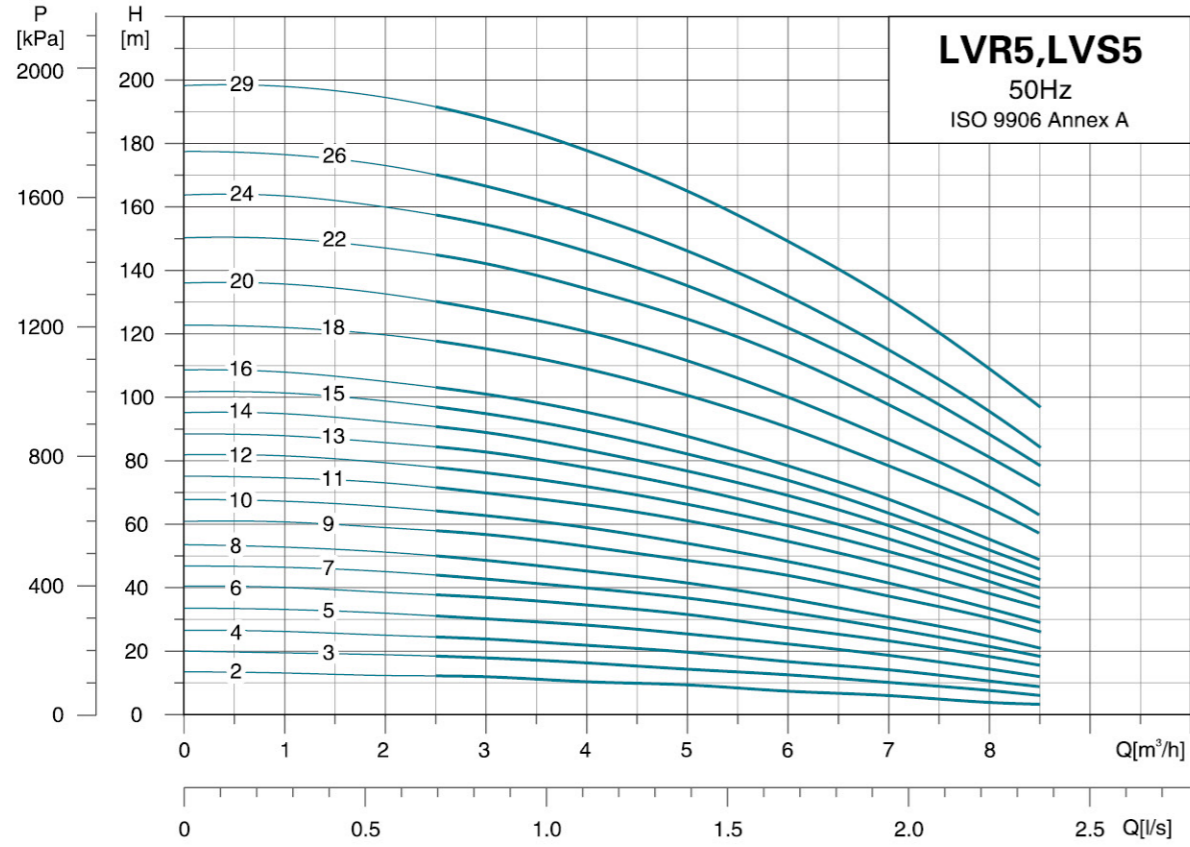

Dimension Drawing

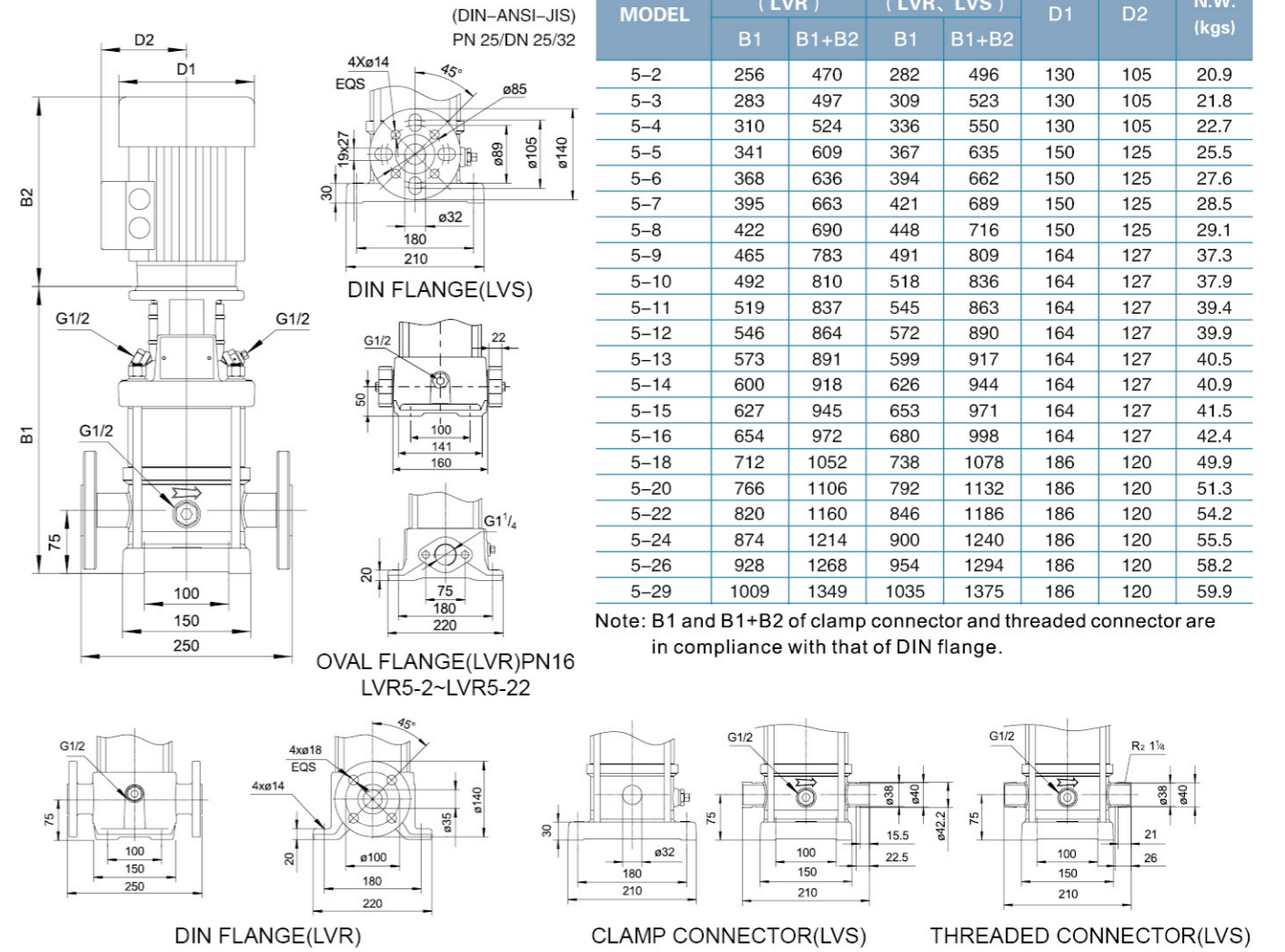

MODEL	OVAL FLANGE (LVR)		DIN FLANGE (LVR, LVS)		D1	D2	N.W. (kgs)
	B1	B1+B2	B1	B1+B2			
5-2	256	470	282	496	130	105	20.9
5-3	283	497	309	523	130	105	21.8
5-4	310	524	336	550	130	105	22.7
5-5	341	609	367	635	150	125	25.5
5-6	368	636	394	662	150	125	27.6
5-7	395	663	421	689	150	125	28.5
5-8	422	690	448	716	150	125	29.1
5-9	465	783	491	809	164	127	37.3
5-10	492	810	518	836	164	127	37.9
5-11	519	837	545	863	164	127	39.4
5-12	546	864	572	890	164	127	39.9
5-13	573	891	599	917	164	127	40.5
5-14	600	918	626	944	164	127	40.9
5-15	627	945	653	971	164	127	41.5
5-16	654	972	680	998	164	127	42.4
5-18	712	1052	738	1078	186	120	49.9
5-20	766	1106	792	1132	186	120	51.3
5-22	820	1160	846	1186	186	120	54.2
5-24	874	1214	900	1240	186	120	55.5
5-26	928	1268	954	1294	186	120	58.2
5-29	1009	1349	1035	1375	186	120	59.9

Note: B1 and B1+B2 of clamp connector and threaded connector are in compliance with that of DIN flange.

MODEL	POWER[kW]	Q[m³/h]	2.5	3.0	4.0	5.0	6.0	7.0	8.0	8.5
LVR(S)5-2	0.37	12	12	10	9	7	6	4	3.5	
LVR(S)5-3	0.55	19	18	16	15	12	10	8	6	
LVR(S)5-4	0.55	24	24	22	19	16	14	10.5	9	
LVR(S)5-5	0.75	31	30	28	24	22	18	15	12	
LVR(S)5-6	1.1	38	37	34	28	27	23	19	15	
LVR(S)5-7	1.1	44	42	40	32	32	27	22	19	
LVR(S)5-8	1.1	50	48	45	40	36	31	25	21	
LVR(S)5-9	1.5	59	56	53	47	44	37	31	26	
LVR(S)5-10	1.5	65	62	59	53	48	41	34	29	
LVR(S)5-11	2.2	73	70	66	59	54	47	38	35	
LVR(S)5-12	2.2	78	76	72	63	59	51	42	38	
LVR(S)5-13	2.2	85	82	78	68	64	55	45	40	
LVR(S)5-14	2.2	91	89	83	74	69	60	58	53	
LVR(S)5-15	2.2	98	95	89	79	74	63	52	46	
LVR(S)5-16	2.2	103	101	95	85	78	68	55	49	
LVR(S)5-18	3	118	115	109	98	90	78	65	58	
LVR(S)5-20	3	130	127	120	108	100	87	72	64	
LVR(S)5-22	4	145	142	134	120	112	97	80	72	
LVR(S)5-24	4	158	154	146	132	122	106	88	78	
LVR(S)5-26	4	170	166	157	145	132	115	95	85	
LVR(S)5-29	4	192	188	178	155	149	131	109	98	

Hydraulic Performance Curves

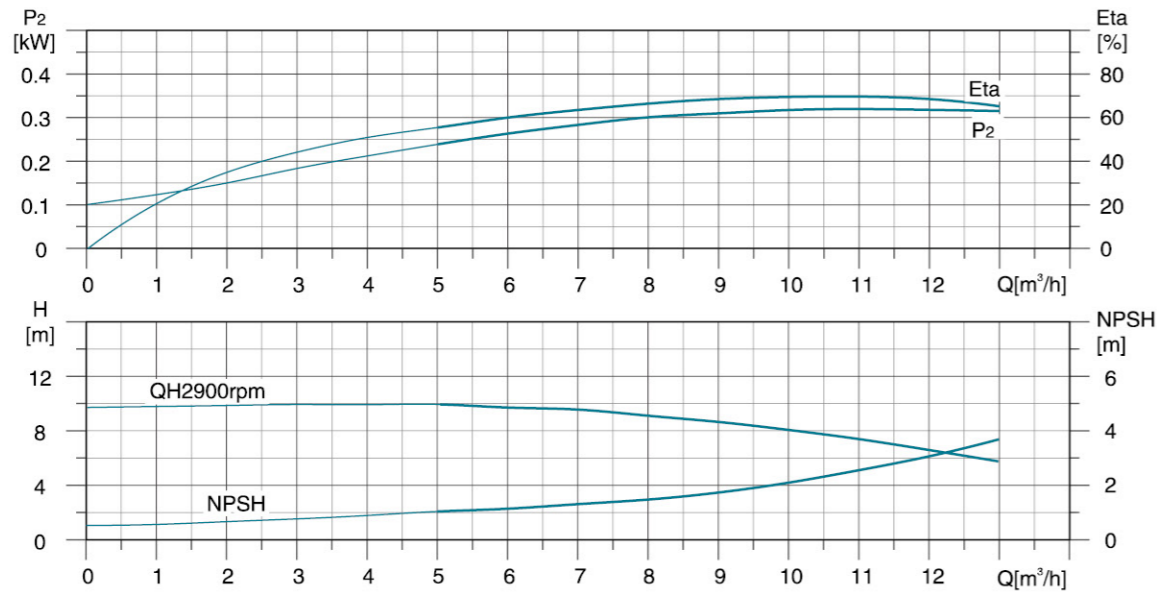
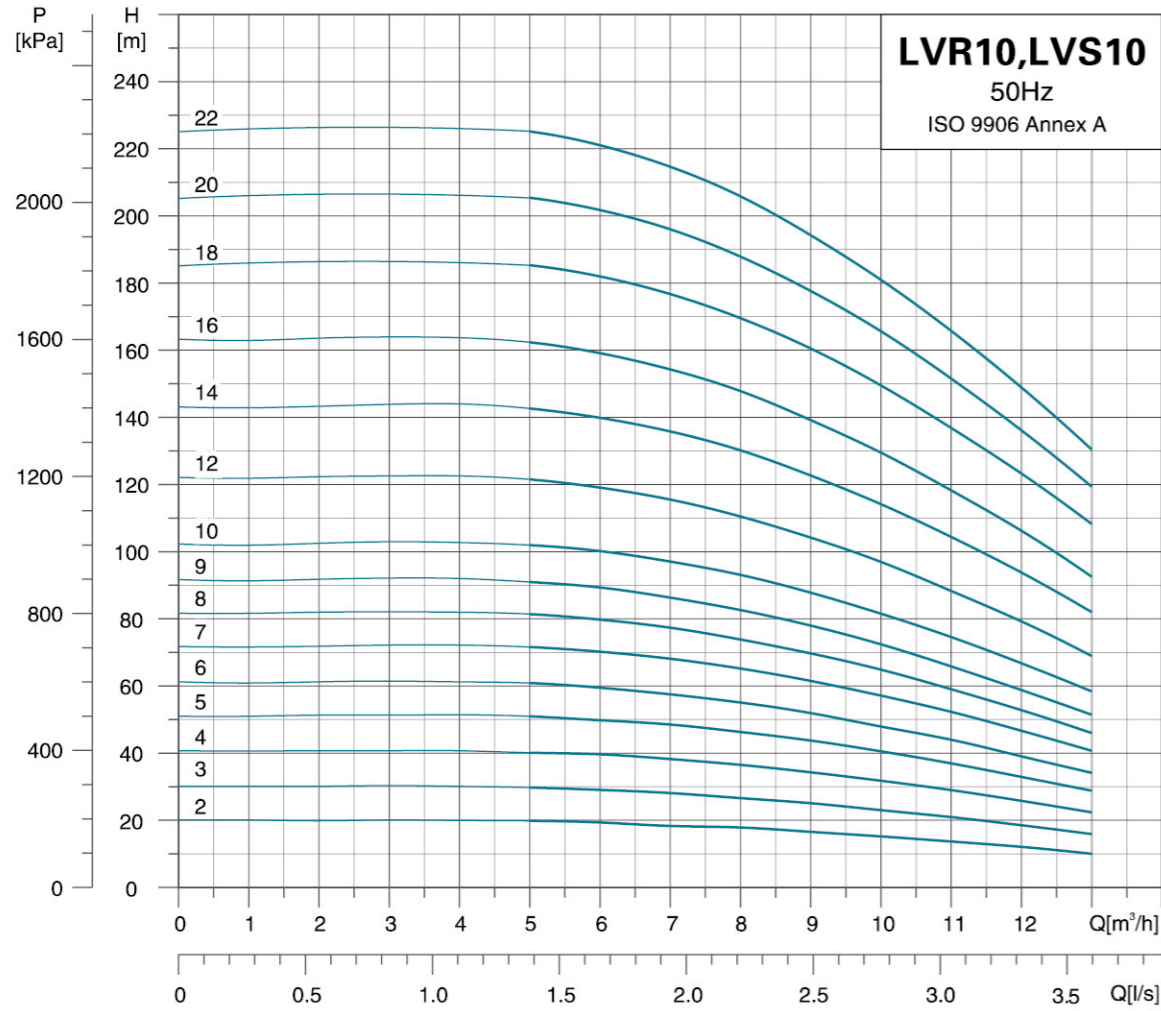

Dimension Drawing

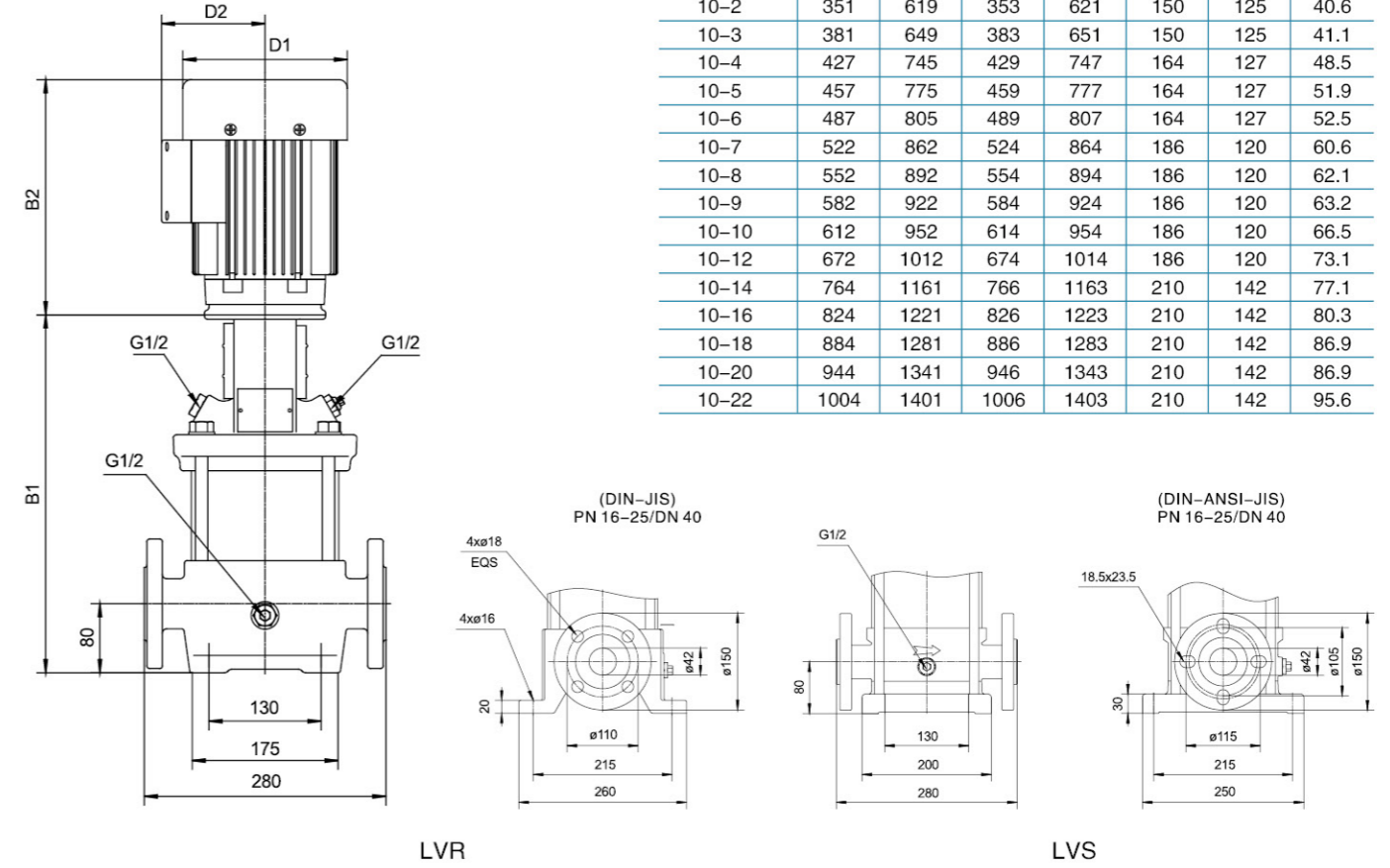

MODEL	DIN FLANGE (LVR)		DIN FLANGE (LVS)		D1	D2	N.W. (kgs)
	B1	B1+B2	B1	B1+B2			
10-2	351	619	353	621	150	125	40.6
10-3	381	649	383	651	150	125	41.1
10-4	427	745	429	747	164	127	48.5
10-5	457	775	459	777	164	127	51.9
10-6	487	805	489	807	164	127	52.5
10-7	522	862	524	864	186	120	60.6
10-8	552	892	554	894	186	120	62.1
10-9	582	922	584	924	186	120	63.2
10-10	612	952	614	954	186	120	66.5
10-12	672	1012	674	1014	186	120	73.1
10-14	764	1161	766	1163	210	142	77.1
10-16	824	1221	826	1223	210	142	80.3
10-18	884	1281	886	1283	210	142	86.9
10-20	944	1341	946	1343	210	142	86.9
10-22	1004	1401	1006	1403	210	142	95.6

MODEL	POWER[kW]	Q[m³/h]	5.0	6.0	8.0	10	12	13
LVR(S)10-2	0.75		20	19	18	15	12	10
LVR(S)10-3	1.1		30	29	26	23	18	16
LVR(S)10-4	1.5		40	40	36	32	26	23
LVR(S)10-5	2.2		51	50	46	40	33	29
LVR(S)10-6	2.2		61	59	55	48	39	35
LVR(S)10-7	3		72	70	65	56	46	41
LVR(S)10-8	3		82	80	74	64	53	46
LVR(S)10-9	3		92	89	82	70	59	52
LVR(S)10-10	4		102	100	93	80	66	59
LVR(S)10-12	4		122	119	110	95	79	69
LVR(S)10-14	5.5		142	140	130	113	94	82
LVR(S)10-16	5.5		162	159	148	128	106	93
LVR(S)10-18	7.5		185	182	169	147	123	109
LVR(S)10-20	7.5		206	201	188	164	136	119
LVR(S)10-22	7.5		226	221	206	178	147	130

Hydraulic Performance Curves

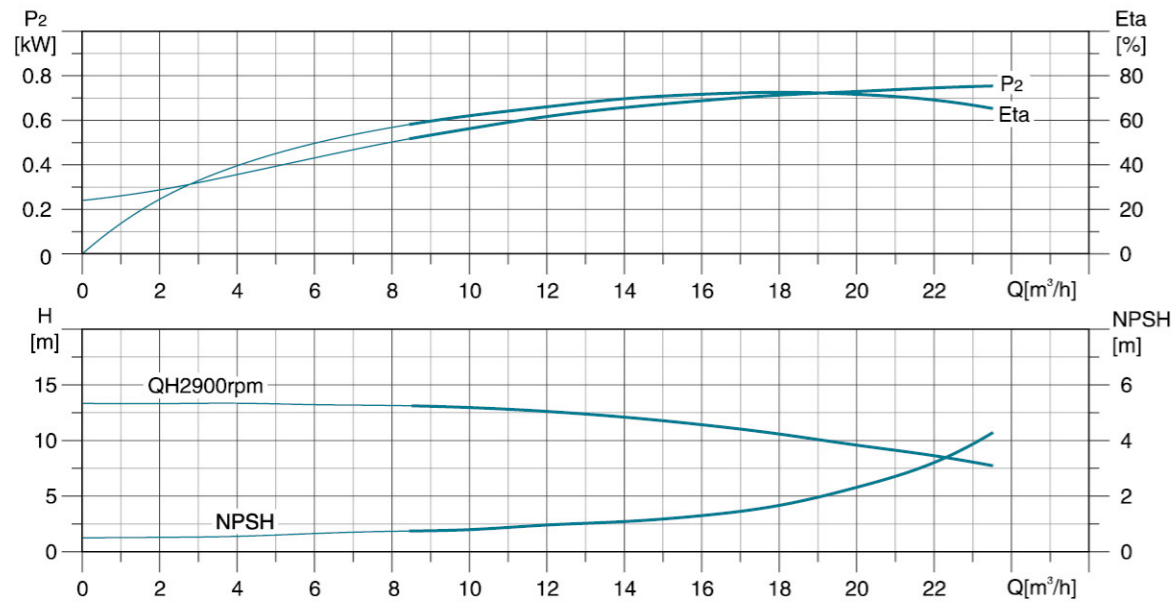
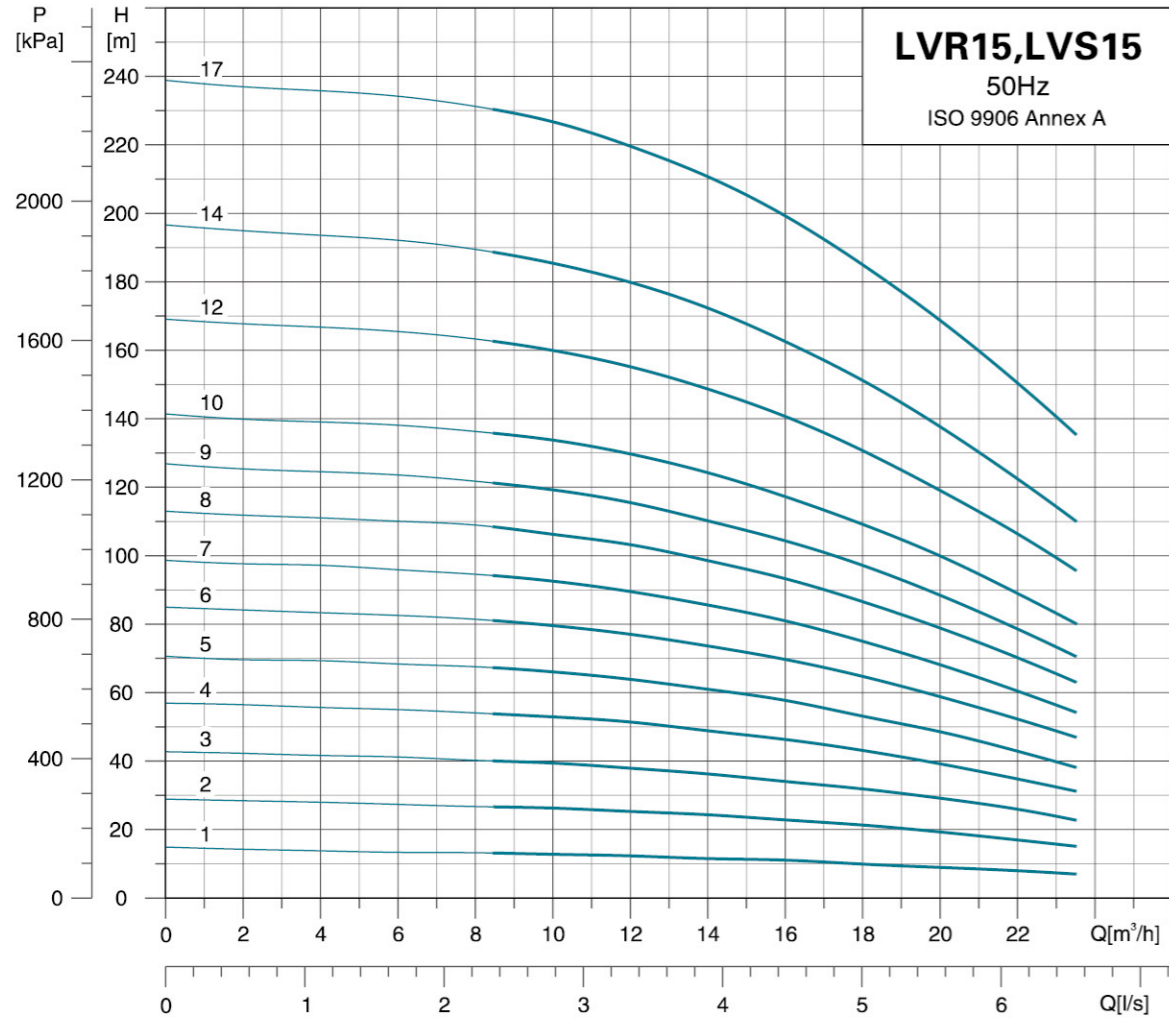

Dimension Drawing

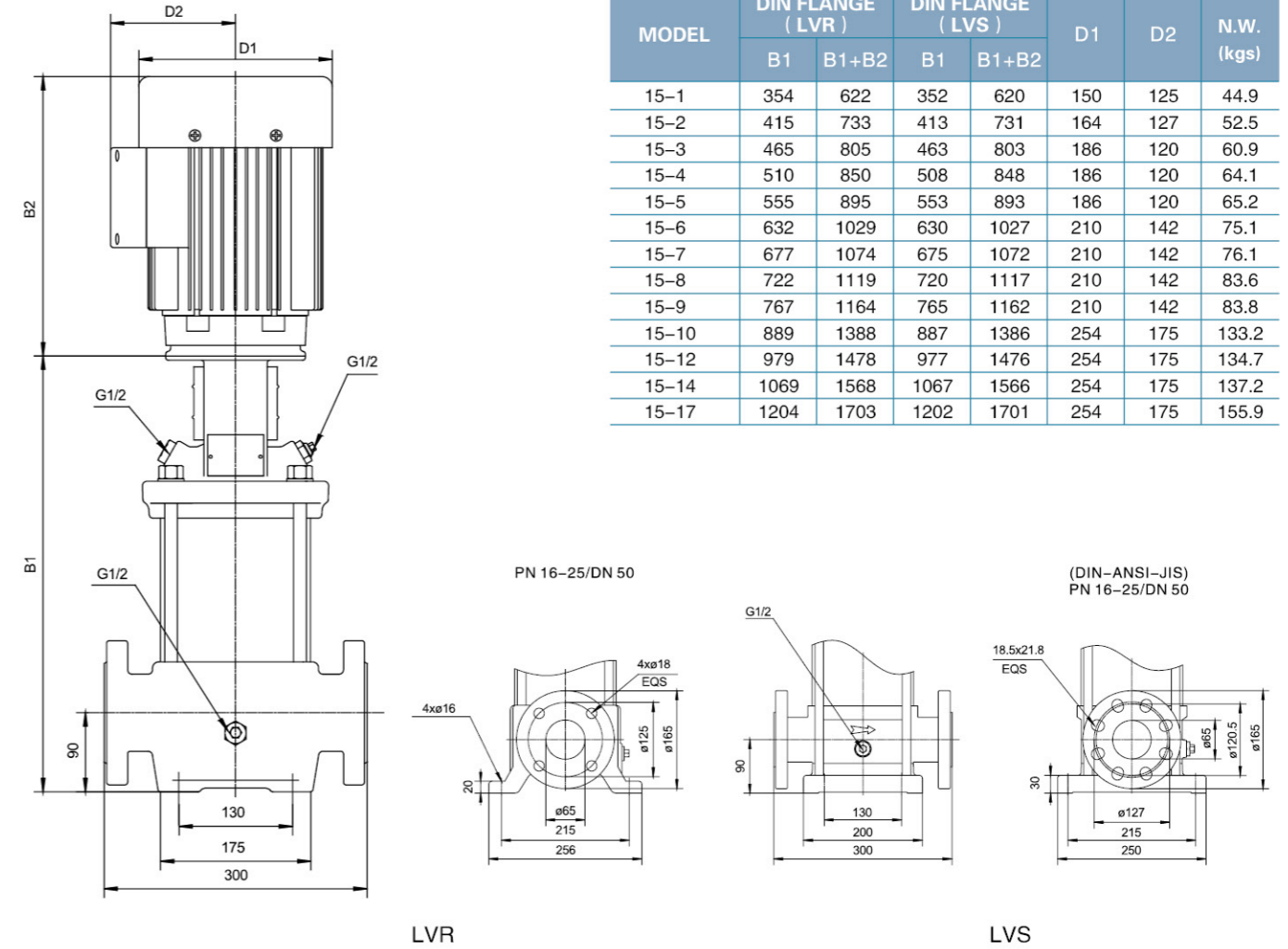

MODEL	DIN FLANGE (LVR)		DIN FLANGE (LVS)		D1	D2	N.W. (kgs)
	B1	B1+B2	B1	B1+B2			
15-1	354	622	352	620	150	125	44.9
15-2	415	733	413	731	164	127	52.5
15-3	465	805	463	803	186	120	60.9
15-4	510	850	508	848	186	120	64.1
15-5	555	895	553	893	186	120	65.2
15-6	632	1029	630	1027	210	142	75.1
15-7	677	1074	675	1072	210	142	76.1
15-8	722	1119	720	1117	210	142	83.6
15-9	767	1164	765	1162	210	142	83.8
15-10	889	1388	887	1386	254	175	133.2
15-12	979	1478	977	1476	254	175	134.7
15-14	1069	1568	1067	1566	254	175	137.2
15-17	1204	1703	1202	1701	254	175	155.9

MODEL	POWER[kW]	Q[m³/h]	8.5	12	15	18	21	23.5
LVR(S)15-1	1.1		13	12	11	10	9	7
LVR(S)15-2	2.2		26	25	23	21	18	15
LVR(S)15-3	3		40	38	35	32	28	22
LVR(S)15-4	4		55	51	47	43	38	32
LVR(S)15-5	4		68	64	58	53	48	38
LVR(S)15-6	5.5		81	77	71	64	58	47
LVR(S)15-7	5.5		95	89	83	75	65	52
LVR(S)15-8	7.5		108	103	96	86	75	62
LVR(S)15-9	7.5		121	115	108	97	84	70
LVR(S)15-10	11		136	129	120	109	95	80
LVR(S)15-12	11		164	155	142	130	114	95
LVR(S)15-14	11		189	180	166	151	130	110
LVR(S)15-17	15		231	219	205	185	160	135

Hydraulic Performance Curves

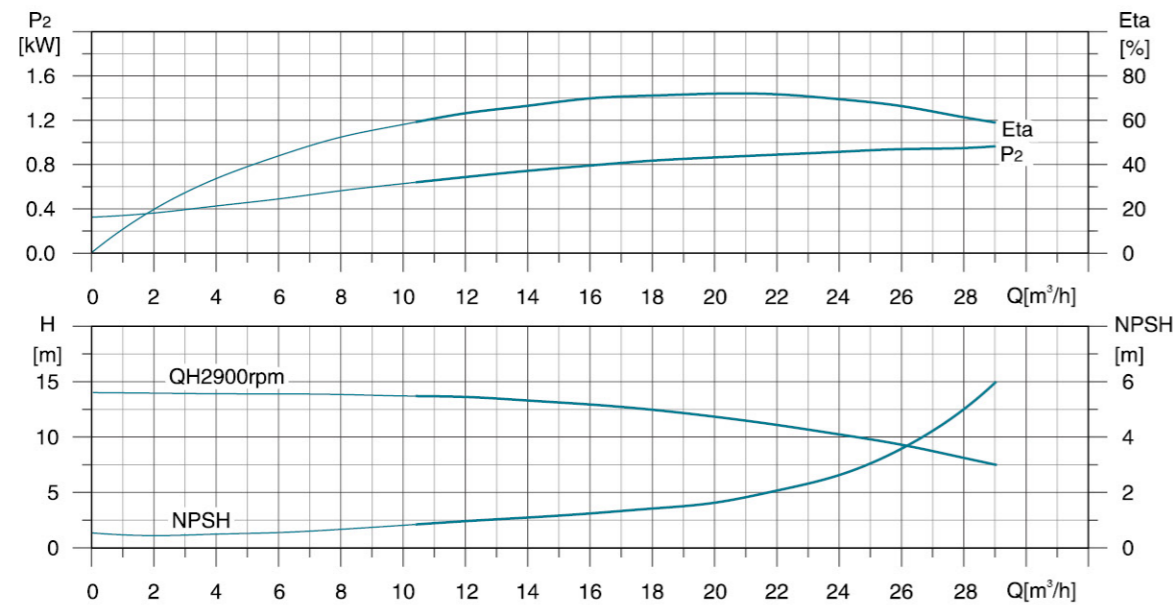
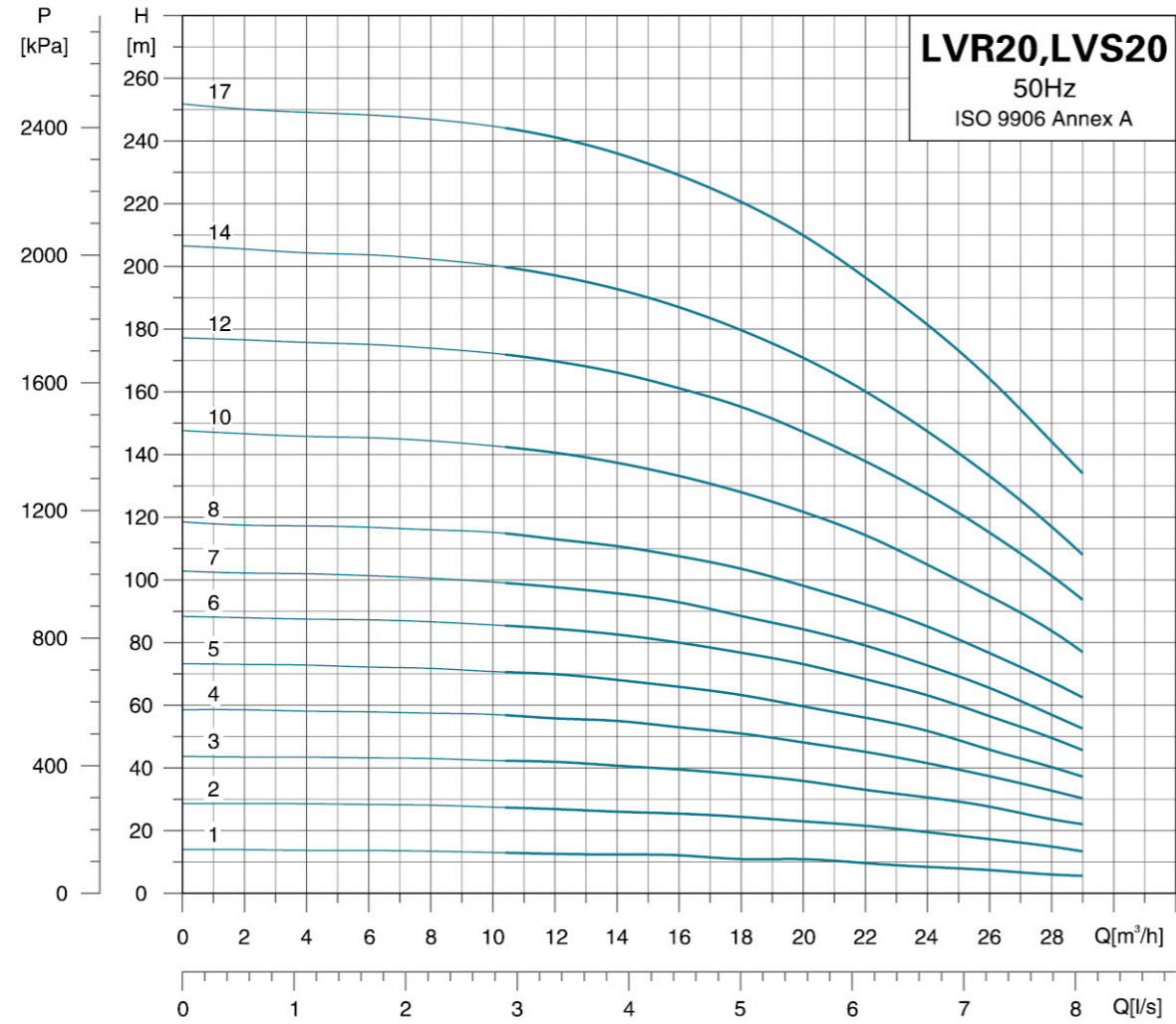

Dimension Drawing

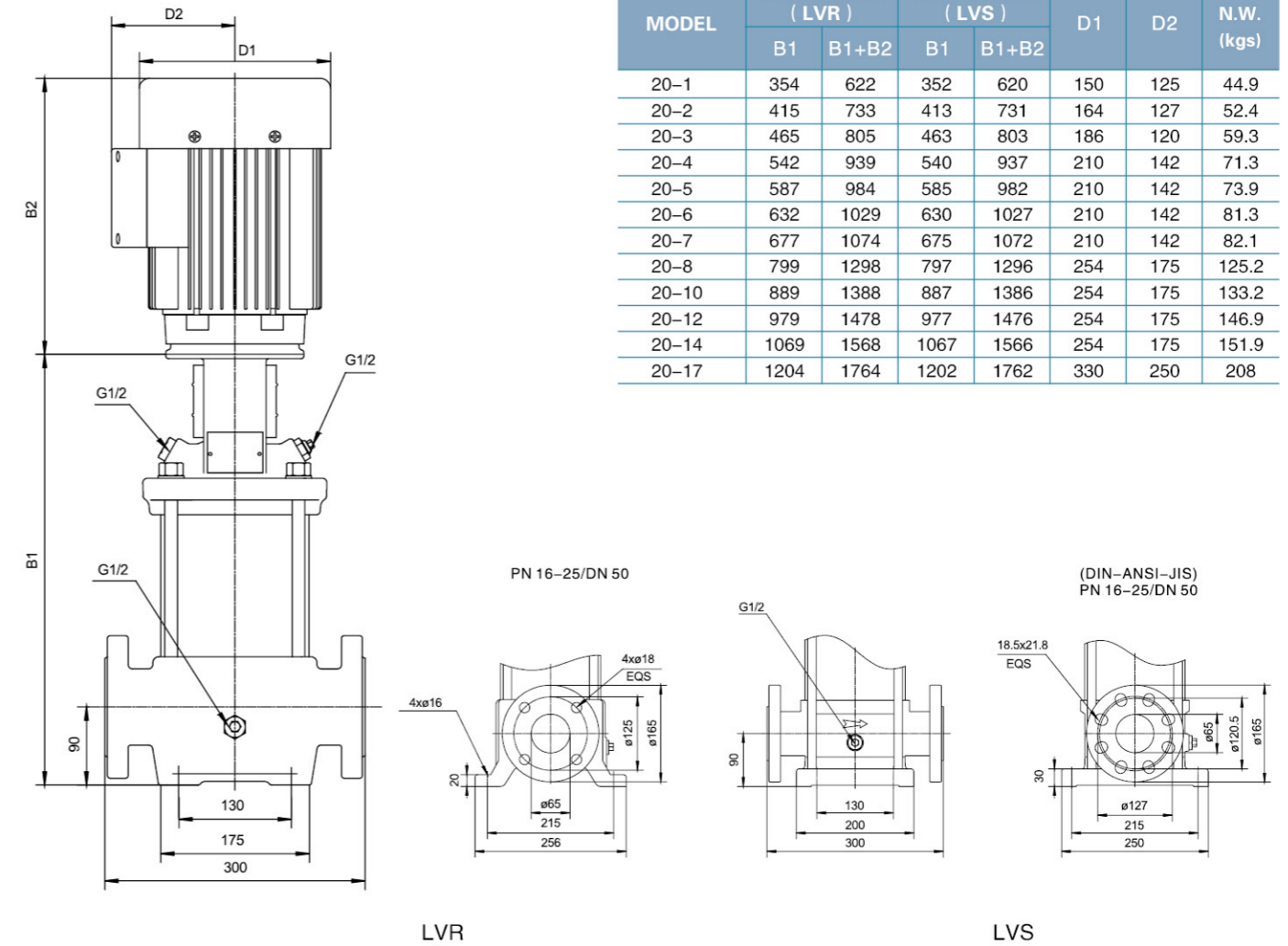

MODEL	DIN FLANGE (LVR)		DIN FLANGE (LVS)		D1	D2	N.W. (kgs)
	B1	B1+B2	B1	B1+B2			
20-1	354	622	352	620	150	125	44.9
20-2	415	733	413	731	164	127	52.4
20-3	465	805	463	803	186	120	59.3
20-4	542	939	540	937	210	142	71.3
20-5	587	984	585	982	210	142	73.9
20-6	632	1029	630	1027	210	142	81.3
20-7	677	1074	675	1072	210	142	82.1
20-8	799	1298	797	1296	254	175	125.2
20-10	889	1388	887	1386	254	175	133.2
20-12	979	1478	977	1476	254	175	146.9
20-14	1069	1568	1067	1566	254	175	151.9
20-17	1204	1764	1202	1762	330	250	208

MODEL	POWER[kW]	Q[m³/h]	10.5	12	16	20	24	28	28.5
LVR(S)20-1	1.1		13	13	12	10.5	9	6.5	6
LVR(S)20-2	2.2		28	27	25	22.5	19	15	13
LVR(S)20-3	4		42	42	39	36	30	23	22
LVR(S)20-4	5.5		58	56	53	48	41	32	30
LVR(S)20-5	5.5		71	70	66	60	52	40	38
LVR(S)20-6	7.5		86	84	80	72	62	49	45
LVR(S)20-7	7.5		99	97	93	84	72	57	52
LVR(S)20-8	11		115	113	107	96	85	67	63
LVR(S)20-10	11		142	140	132	120	105	83	78
LVR(S)20-12	15		172	169	161	144	127	101	94
LVR(S)20-14	15		200	197	187	168	147	117	109
LVR(S)20-17	18.5		245	241	229	205	181	144	135

Hydraulic Performance Curves

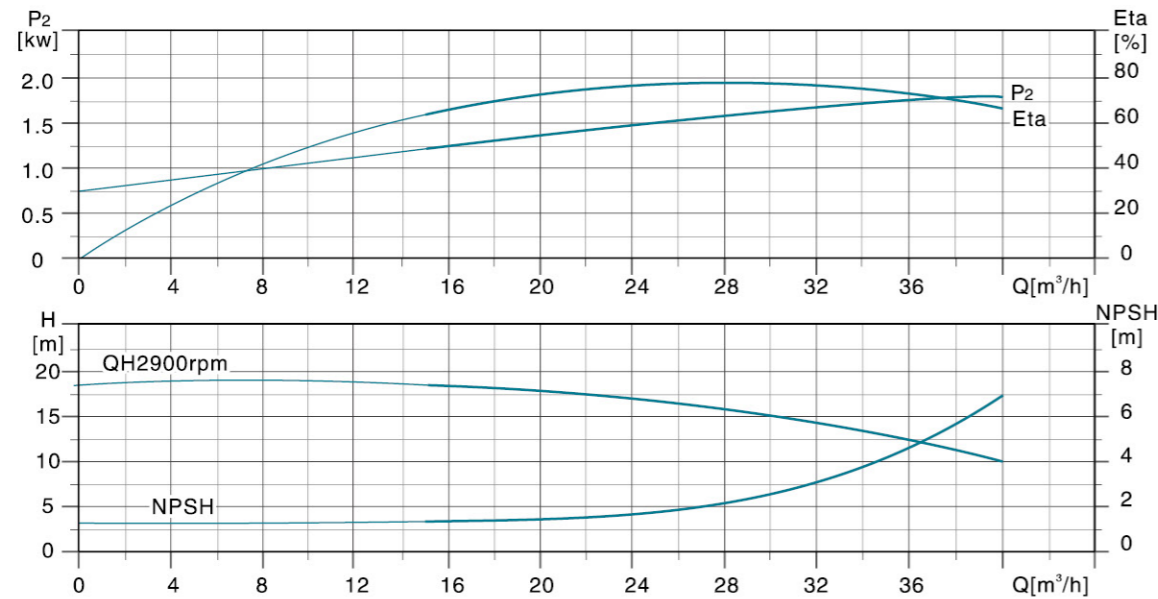
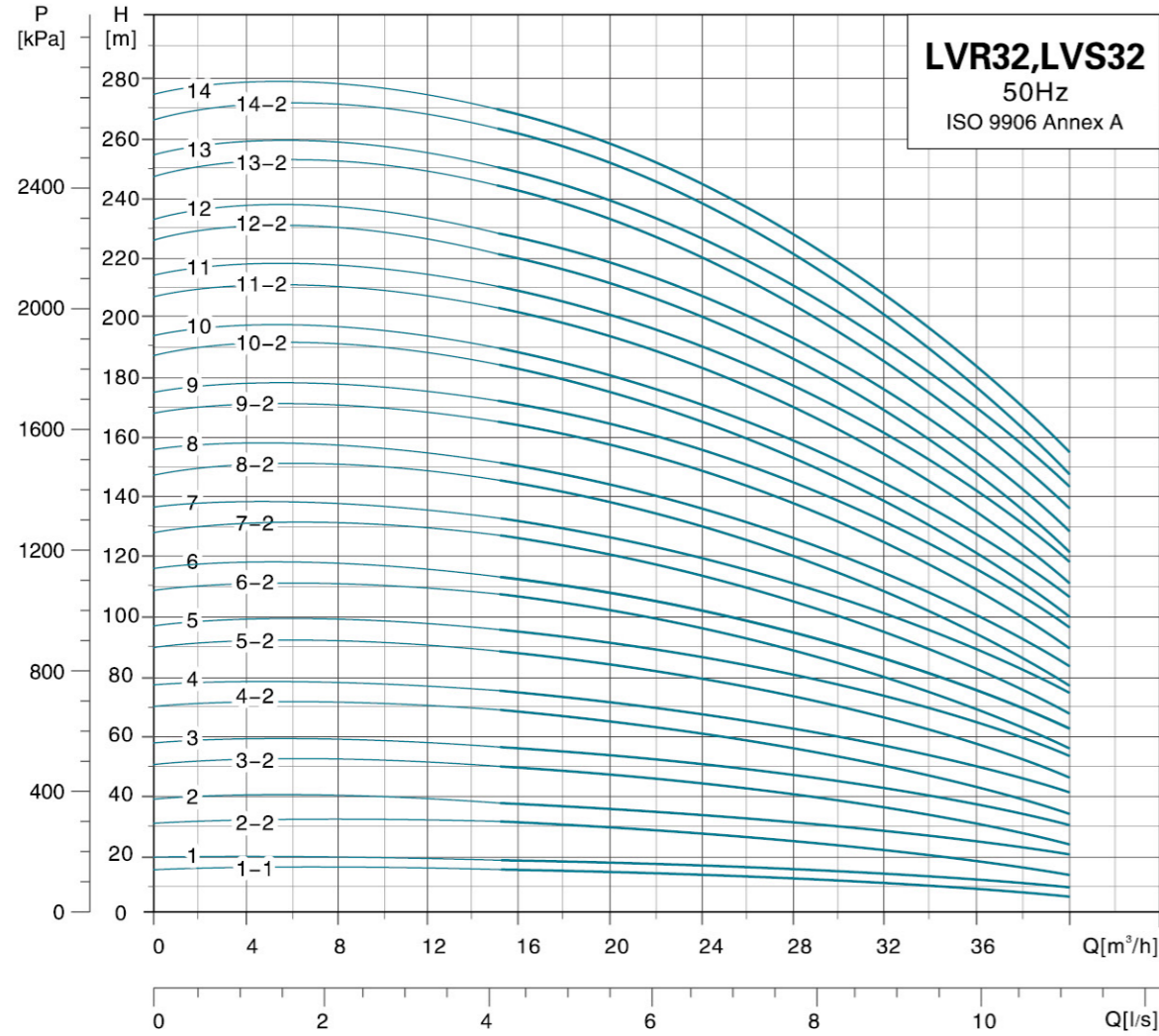

Dimension Drawing

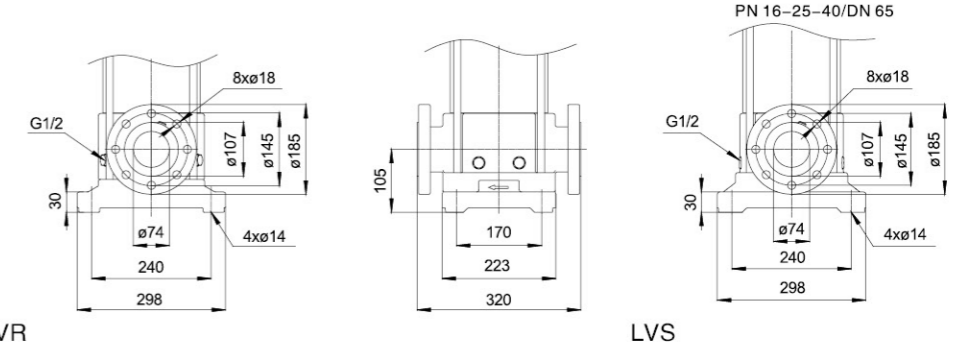
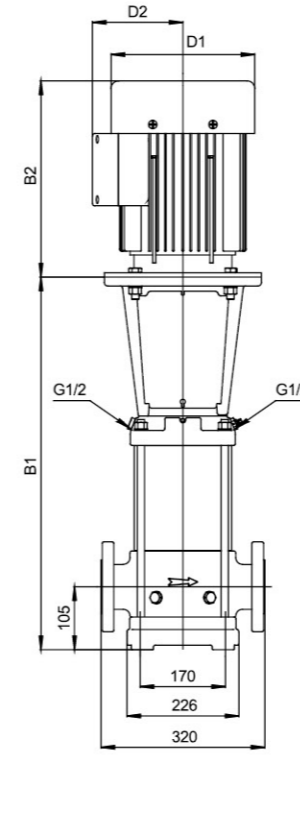

MODEL	DIN FLANGE(LVR, LVS)		D1	D2	N.W. (kgs)
	B1	B1+B2			
32-1-1	455	773	164	127	61.7
32-1	455	773	164	127	63.7
32-2-2	525	865	186	120	72.6
32-2	525	865	186	120	74.9
32-3-2	645	1042	210	142	100.9
32-3	645	1042	210	142	100.6
32-4-2	715	1112	210	142	108.7
32-4	715	1112	210	142	108.7
32-5-2	895	1394	254	175	149.2
32-5	895	1394	254	175	149.2
32-6-2	965	1464	254	175	152.1
32-6	965	1464	254	175	152.1
32-7-2	1035	1534	254	175	167.6
32-7	1035	1534	254	175	167.6
32-8-2	1105	1604	254	175	170.7
32-8	1105	1604	254	175	170.7
32-9-2	1175	1735	330	250	221.6
32-9	1175	1735	330	250	221.6
32-10-2	1245	1805	330	250	224.5
32-10	1245	1805	330	250	224.5
32-11-2	1315	1915	380	280	263.3
32-11	1315	1915	380	280	263.4
32-12-2	1385	1985	380	280	266.2
32-12	1385	1985	380	280	266.2
32-13-2	1455	2135	420	305	323.6
32-13	1455	2135	420	305	323.6
32-14-2	1525	2205	420	305	326.5
32-14	1525	2205	420	305	326.5

MODEL	POWER[kW]	Q[m³/h]	15	20	25	32	35	40
LVR(S)32-1-1	1.5		15	14	13	10	8	5
LVR(S)32-1	2.2		18	17	16	13	11.5	9
LVR(S)32-2-2	3		31	29.5	26.5	20.5	17.5	12
LVR(S)32-2	4		37	35.5	32.5	27.5	25	19.5
LVR(S)32-3-2	5.5		50	47	43.5	35.5	31	22.5
LVR(S)32-3	5.5		55.5	53	49	41.5	37.5	29.5
LVR(S)32-4-2	7.5		68.5	65	60	49.5	44	32.5
LVR(S)32-4	7.5		74.5	70.5	66	56	50.5	40
LVR(S)32-5-2	11		88.5	84.5	78	65.5	58.5	45
LVR(S)32-5	11		94.5	90	84	72	65	52
LVR(S)32-6-2	11		107	102	94.5	79.5	71	55
LVR(S)32-6	11		113	108	100	85.5	77.5	61.5
LVR(S)32-7-2	15		127	121	112	94.5	85	66.5
LVR(S)32-7	15		133	126	118	101	92	73.5
LVR(S)32-8-2	15		145	138	128	108	98	76.5
LVR(S)32-8	15		151	144	134	115	104	83
LVR(S)32-9-2	18.5		165	158	147	124	112	88.5
LVR(S)32-9	18.5		171	163	152	131	119	95.5
LVR(S)32-10-2	18.5		184	175	163	138	125	98.5
LVR(S)32-10	18.5		190	181	169	145	133	106
LVR(S)32-11-2	22		203	194	181	154	140	111
LVR(S)32-11	22		209	200	187	161	147	118
LVR(S)32-12-2	22		222	212	197	168	152	121
LVR(S)32-12	22		227	217	203	176	160	128
LVR(S)32-13-2	30		244	233	218	187	169	136
LVR(S)32-13	30		250	239	224	193	177	145
LVR(S)32-14-2	30		263	251	234	201	183	146
LVR(S)32-14	30		269	258	241	207	188	156

Hydraulic Performance Curves

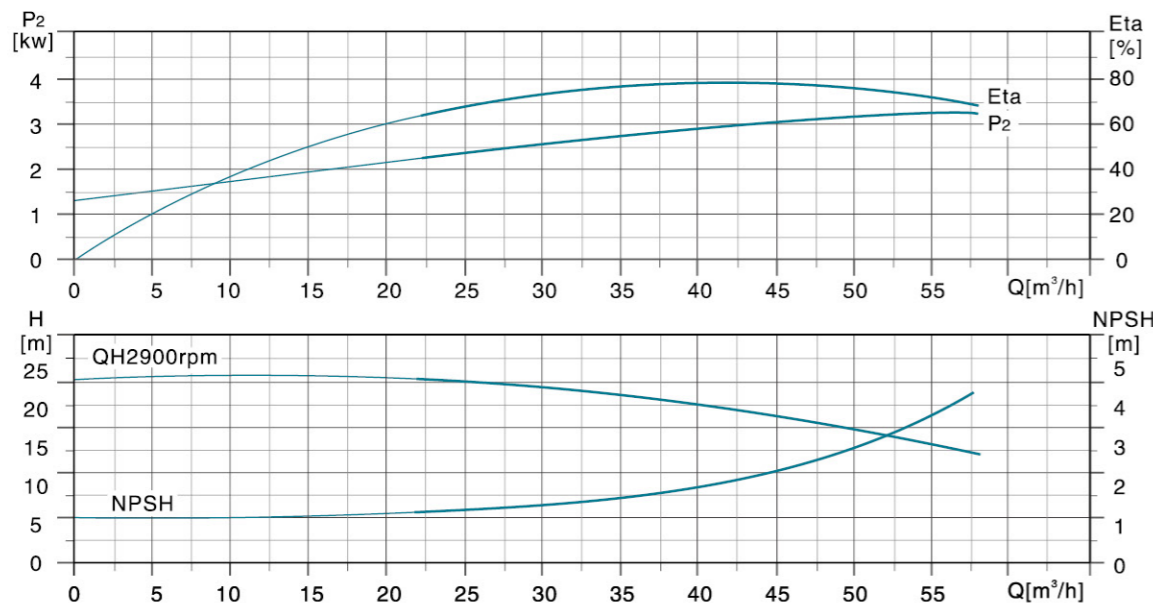
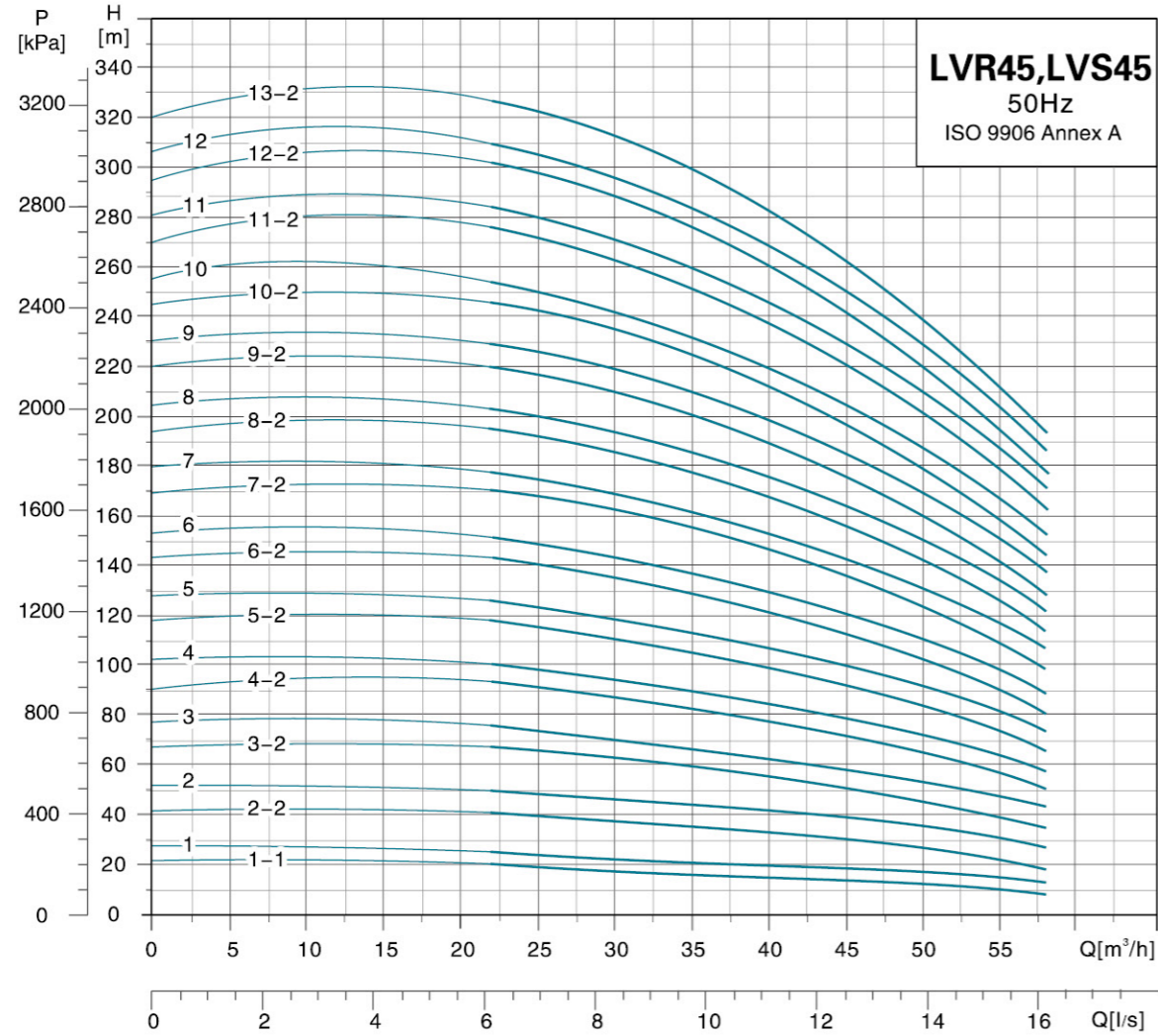

Dimension Drawing

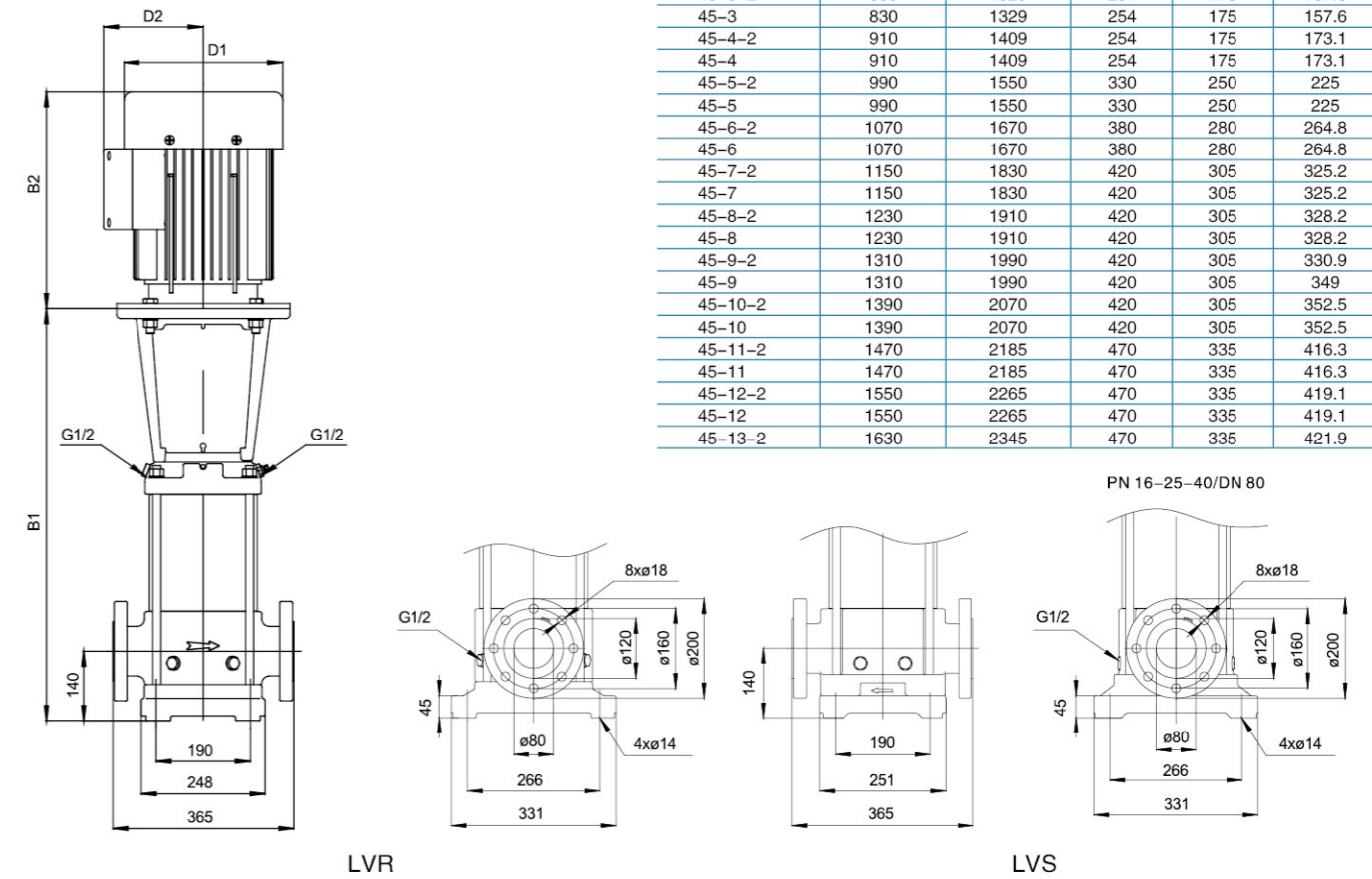

MODEL	DIN FLANGE(LVR, LVS)		D1	D2	N.W. (kgs)
	B1	B1+B2			
45-1-1	560	900	186	120	81
45-1	560	900	186	120	83.2
45-2-2	640	1037	210	142	111.3
45-2	640	1037	210	142	115.5
45-3-2	830	1329	254	175	157.6
45-3	830	1329	254	175	157.6
45-4-2	910	1409	254	175	173.1
45-4	910	1409	254	175	173.1
45-5-2	990	1550	330	250	225
45-5	990	1550	330	250	225
45-6-2	1070	1670	380	280	264.8
45-6	1070	1670	380	280	264.8
45-7-2	1150	1830	420	305	325.2
45-7	1150	1830	420	305	325.2
45-8-2	1230	1910	420	305	328.2
45-8	1230	1910	420	305	328.2
45-9-2	1310	1990	420	305	330.9
45-9	1310	1990	420	305	349
45-10-2	1390	2070	420	305	352.5
45-10	1390	2070	420	305	352.5
45-11-2	1470	2185	470	335	416.3
45-11	1470	2185	470	335	416.3
45-12-2	1550	2265	470	335	419.1
45-12	1550	2265	470	335	419.1
45-13-2	1630	2345	470	335	421.9

MODEL	POWER[kW]	Q[m³/h]	25	30	35	40	45	50	55	58
LVR(S)45-1-1	3		20	19.5	18	17	15	12.5	10.5	8
LVR(S)45-1	4		24	23	22	20.5	19	17.5	15	13
LVR(S)45-2-2	5.5		41	39	37	34	30.5	26.5	22	18
LVR(S)45-2	7.5		48.5	46.5	44.5	42	39	35	31	28
LVR(S)45-3-2	11		66	64	61	56.5	52	46	40	35
LVR(S)45-3	11		73.5	71	68	64	59.5	54	47.5	43
LVR(S)45-4-2	15		91	88	84	78.5	72	64.5	56	50
LVR(S)45-4	15		98.5	95	91	85.5	79.5	72.5	64	59
LVR(S)45-5-2	18.5		116	113	107	101	92.5	83.5	73	66
LVR(S)45-5	18.5		124	120	115	108	100	91.5	81	74
LVR(S)45-6-2	22		142	137	131	122	113	103	90	82
LVR(S)45-6	22		149	144	138	130	121	111	98	90
LVR(S)45-7-2	30		168	163	156	147	135	123	109	99
LVR(S)45-7	30		176	171	163	156	144	132	116	108
LVR(S)45-8-2	30		193	187	179	168	155	142	126	115
LVR(S)45-8	30		200	194	187	176	164	149	134	122
LVR(S)45-9-2	30		217	211	202	189	175	159	142	130
LVR(S)45-9	37		226	219	210	199	185	170	151	140
LVR(S)45-10-2	37		243	236	225	212	196	179	159	146
LVR(S)45-10	37		251	243	233	220	205	187	166	154
LVR(S)45-11-2	45		273	264	253	238	222	201	179	164
LVR(S)45-11	45		281	272	261	246	230	209	187	172
LVR(S)45-12-2	45		298	289	276	261	242	220	195	179
LVR(S)45-12	45		306	296	284	268	251	229	204	188
LVR(S)45-13-2	45		323	313	300	283	263	239	212	195

Hydraulic Performance Curves

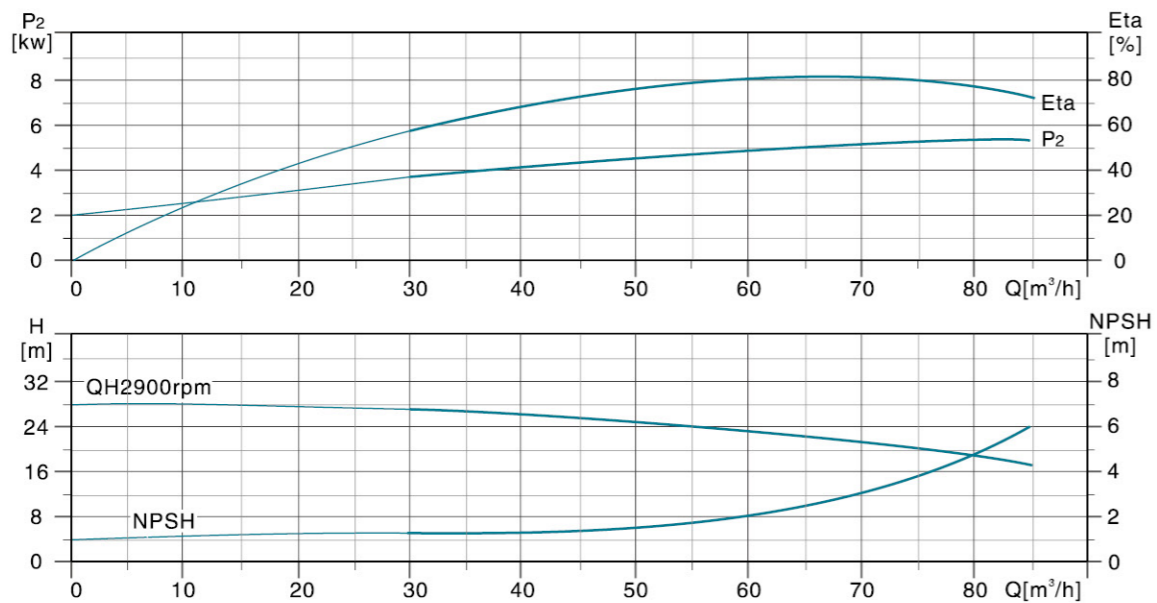
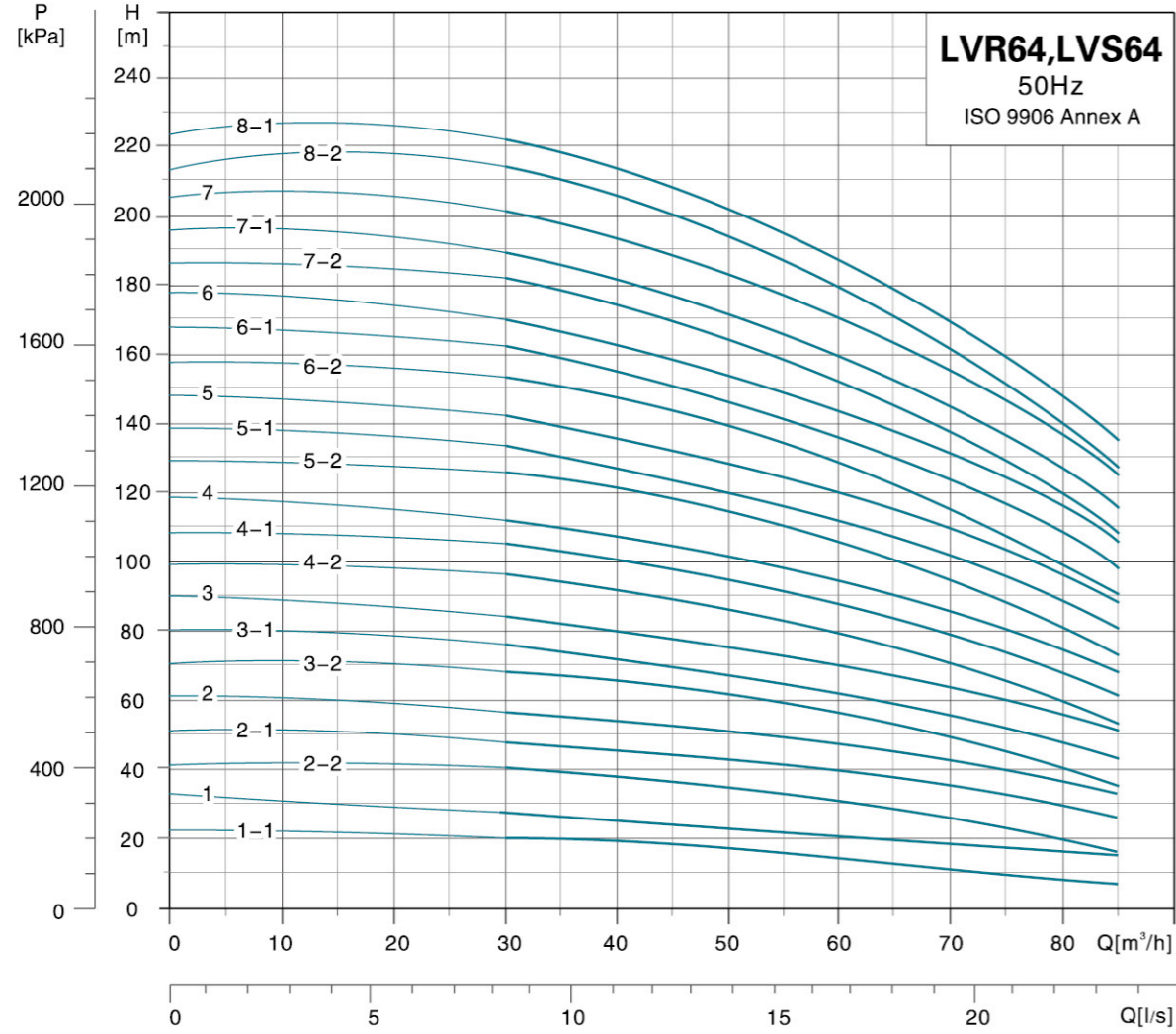

Dimension Drawing

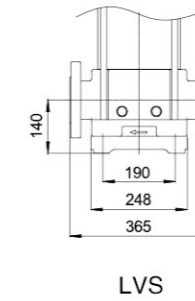
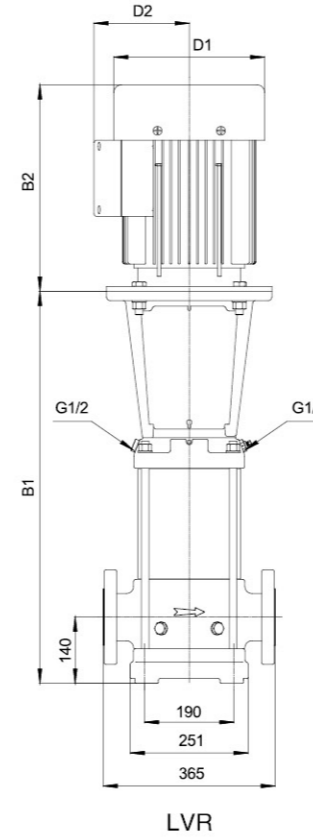

MODEL	DIN FLANGE(LVR, LVS)		D1	D2	N.W. (kgs)
	B1	B1+B2			
64-1-1	563	903	186	124	84.5
64-1	563	960	210	142	110.2
64-2-2	645	1042	210	142	117.4
64-2-1	755	1254	254	175	156
64-2	755	1254	254	175	156
64-3-2	838	1337	254	175	171.9
64-3-1	838	1337	254	175	171.9
64-3	838	1398	330	250	221
64-4-2	920	1480	330	250	223.9
64-4-1	920	1520	380	280	261
64-4	920	1520	380	280	261
64-5-2	1003	1683	420	305	321.5
64-5-1	1003	1683	420	305	321.5
64-5	1003	1683	420	305	321.5
64-6-2	1085	1765	420	305	324.5
64-6-1	1085	1765	420	305	341.2
64-6	1085	1765	420	305	341.2
64-7-2	1168	1848	420	305	344.9
64-7-1	1168	1848	420	305	345
64-7	1168	1883	470	335	407.3
64-8-2	1250	1965	470	335	410.7
64-8-1	1250	1965	470	335	410.4

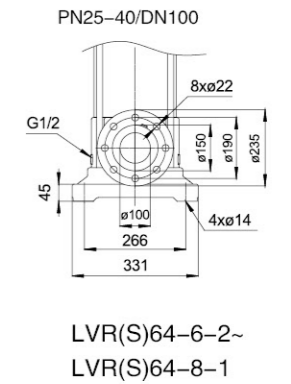
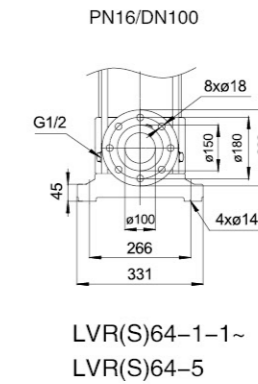

MODEL	POWER[kW]	Q[m³/h]	30	40	50	64	70	80	85
LVR(S)64-1-1	4		20	19	17.5	14	12	8.5	6
LVR(S)64-1	5.5		27	25.5	23.5	21	20	17	15
LVR(S)64-2-2	7.5		40	38	35.5	29	25.5	19	15
LVR(S)64-2-1	11		48	45.5	42.5	37	34.5	29	25
LVR(S)64-2	11		55	52.5	49.5	44	41.5	36	33
LVR(S)64-3-2	15		68	65.5	60	52.5	48.5	40	35
LVR(S)64-3-1	15		75.5	72	67.5	59.5	55.5	47	42
LVR(S)64-3	18.5		83.5	80	76	68	64	56	51
LVR(S)64-4-2	18.5		96	92.5	87	75.5	70	59	52
LVR(S)64-4-1	22		104	100	94.5	83.5	78.5	67.5	61
LVR(S)64-4	22		112	107	102	91	85.5	74.5	69
LVR(S)64-5-2	30		126	122	115	101	94	80.5	73
LVR(S)64-5-1	30		134	129	122	109	102	88	81
LVR(S)64-5	30		141	136	129	116	109	96	89
LVR(S)64-6-2	30		154	148	140	124	115	99	90
LVR(S)64-6-1	37		162	156	148	132	124	108	98
LVR(S)64-6	37		170	163	155	139	131	116	107
LVR(S)64-7-2	37		182	176	166	147	138	119	109
LVR(S)64-7-1	37		190	183	173	155	145	126	110
LVR(S)64-7	45		202	194	184	165	155	136	126
LVR(S)64-8-2	45		214	207	196	174	163	140	128
LVR(S)64-8-1	45		222	214	203	181	170	148	135

Hydraulic Performance Curves

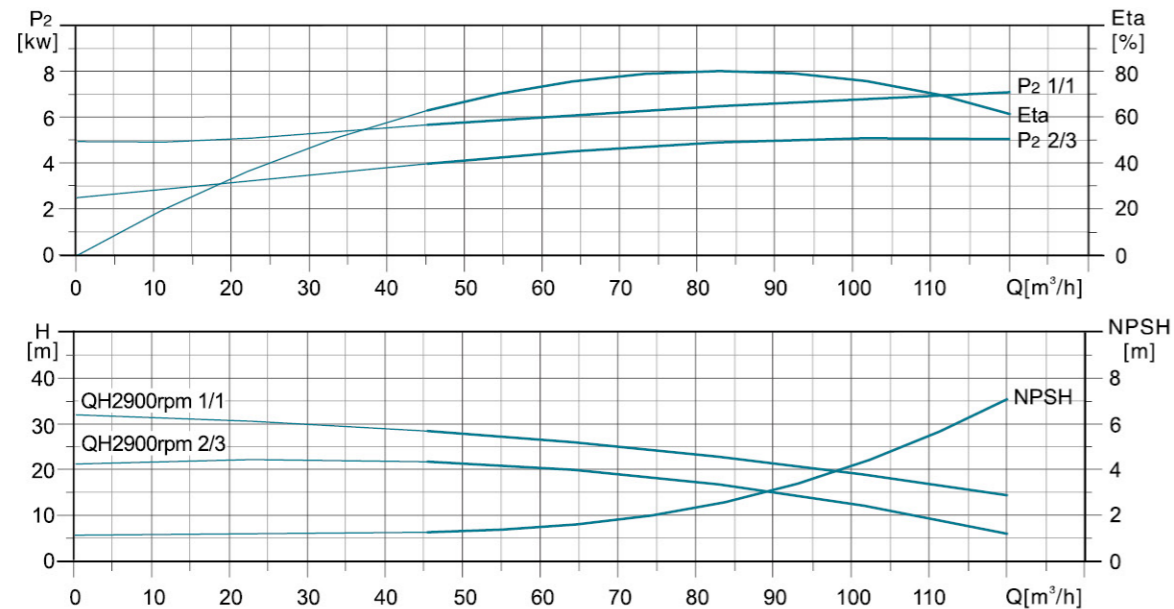
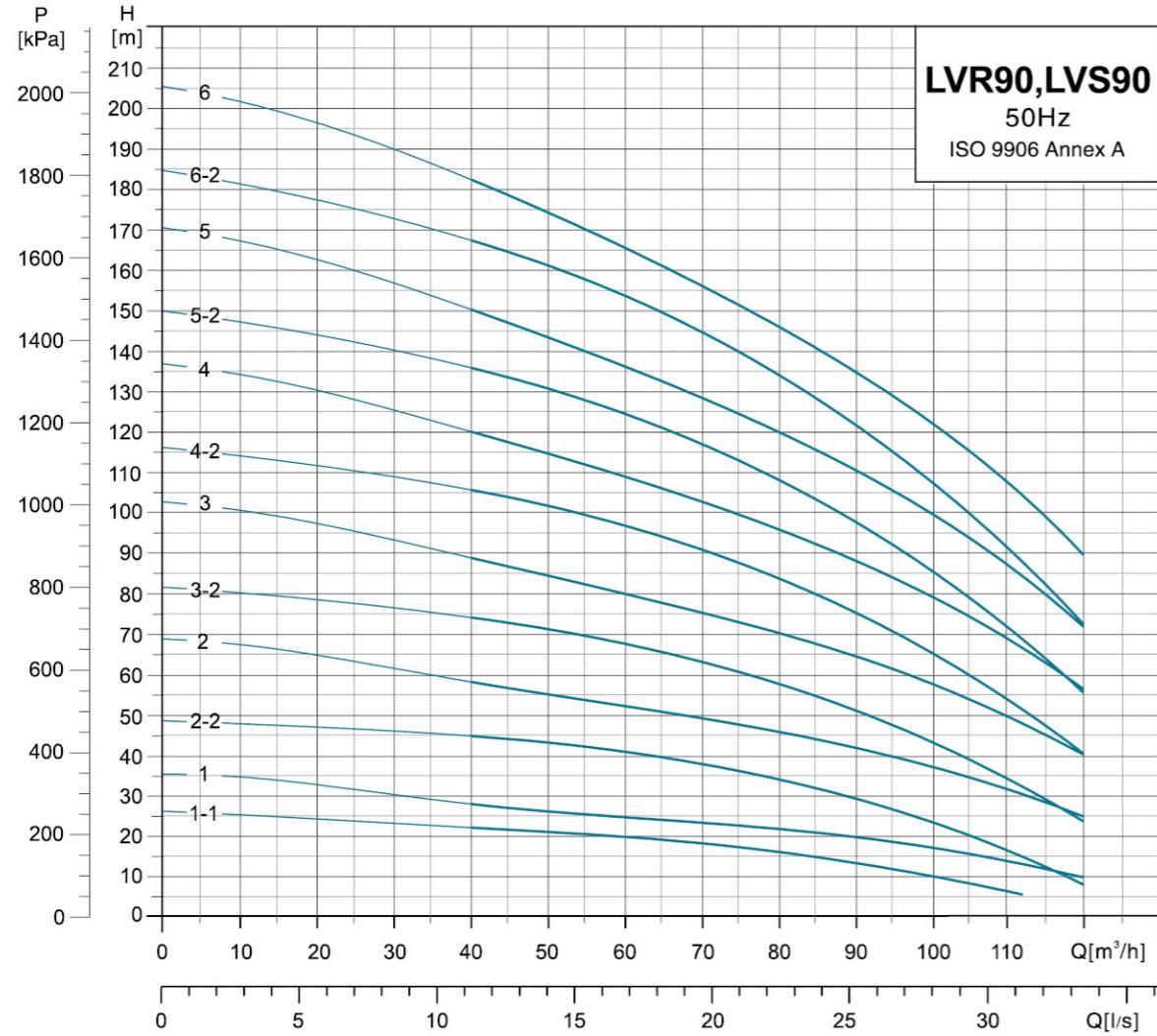

Dimension Drawing

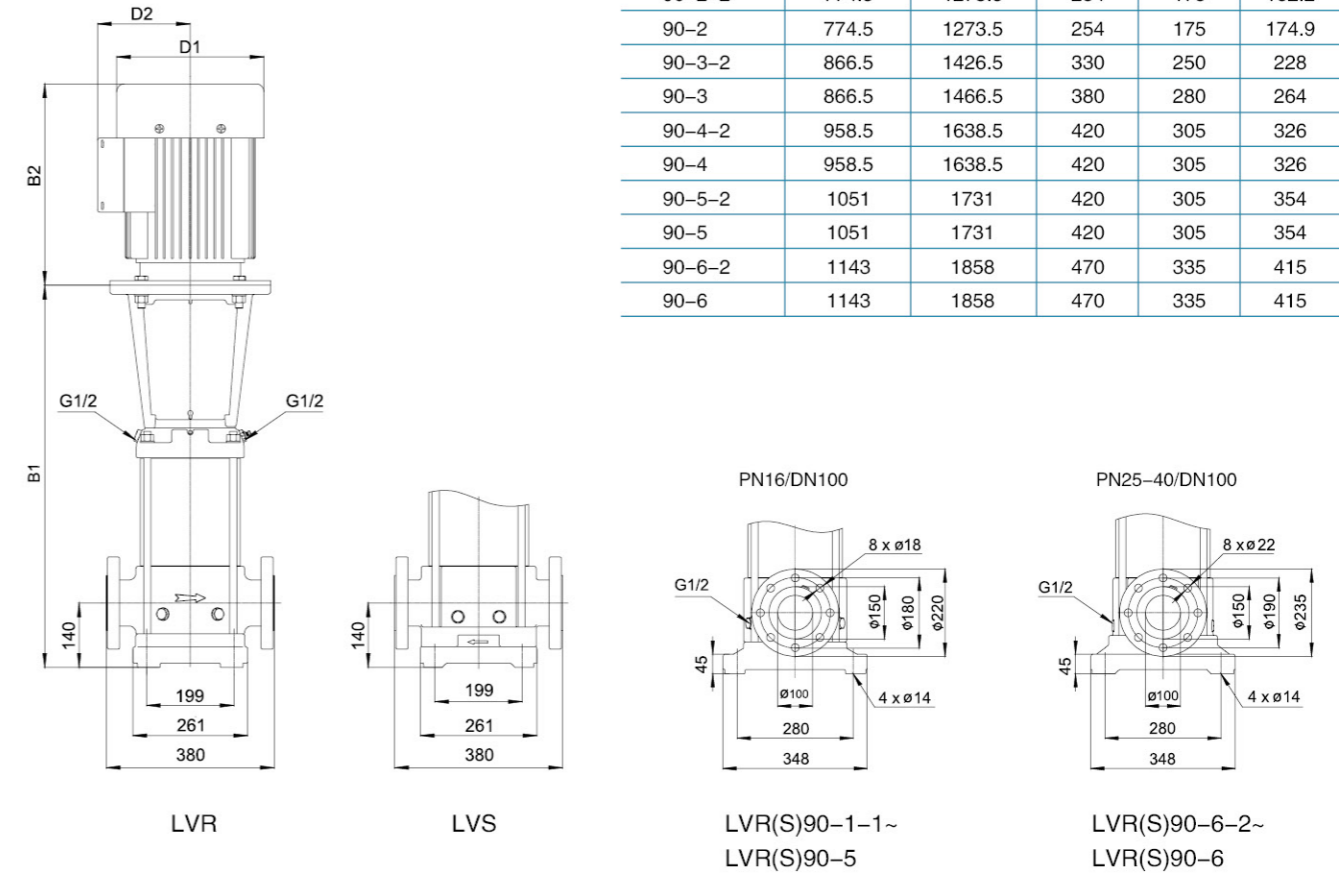

MODEL	DIN FLANGE(LVR, LVS)		D1	D2	N.W. (kgs)
	B1	B1+B2			
90-1-1	572.5	969.5	210	142	116
90-1	572.5	969.5	210	142	121.2
90-2-2	774.5	1273.5	254	175	162.2
90-2	774.5	1273.5	254	175	174.9
90-3-2	866.5	1426.5	330	250	228
90-3	866.5	1466.5	380	280	264
90-4-2	958.5	1638.5	420	305	326
90-4	958.5	1638.5	420	305	326
90-5-2	1051	1731	420	305	354
90-5	1051	1731	420	305	354
90-6-2	1143	1858	470	335	415
90-6	1143	1858	470	335	415

MODEL	POWER[kW]	Q[m³/h]	40	50	60	70	80	90	100	110	120
LVR(S)90-1-1	5.5	H(m)	22	21	20	18	16	14	10.5	6.5	-
LVR(S)90-1	7.5		38	26	25	23.5	22	20	17.5	14	10
LVR(S)90-2-2	11		45	43	41	38	34.5	30	24	17	8
LVR(S)90-2	15		58	55	52	49	46	42.5	37.5	31.5	25
LVR(S)90-3-2	18.5		74	71.5	68	63.5	58	51.5	44	35	24
LVR(S)90-3	22		88	84.5	80	75.5	70.5	65	58.5	50.5	40
LVR(S)90-4-2	30		106	102	97	91	84.5	76	65.5	54	40
LVR(S)90-4	30		120	114	109	103	96	88.5	79.5	69.5	57
LVR(S)90-5-2	37		136	131	125	118	109	98.5	86.5	72	55
LVR(S)90-5	37		150	144	136	129	121	111	101	87	72
LVR(S)90-6-2	45		166	161	154	145	135	123	108	91.5	72
LVR(S)90-6	45		182	175	166	156	146	135	123	108	90

Hydraulic Performance Curves

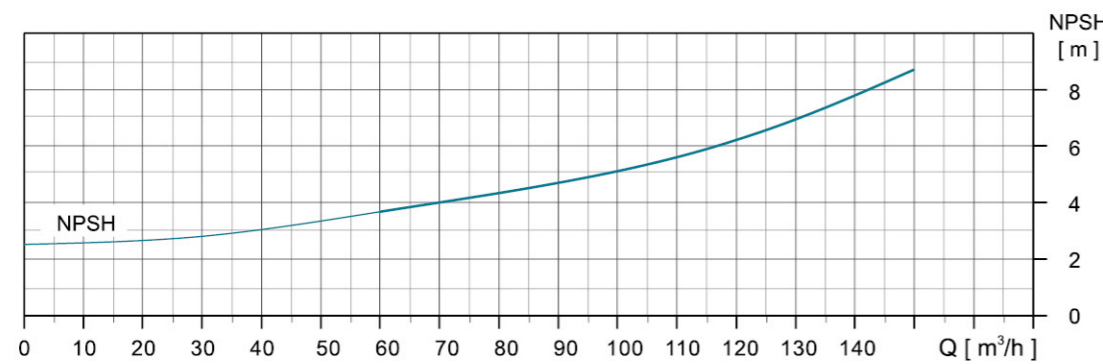
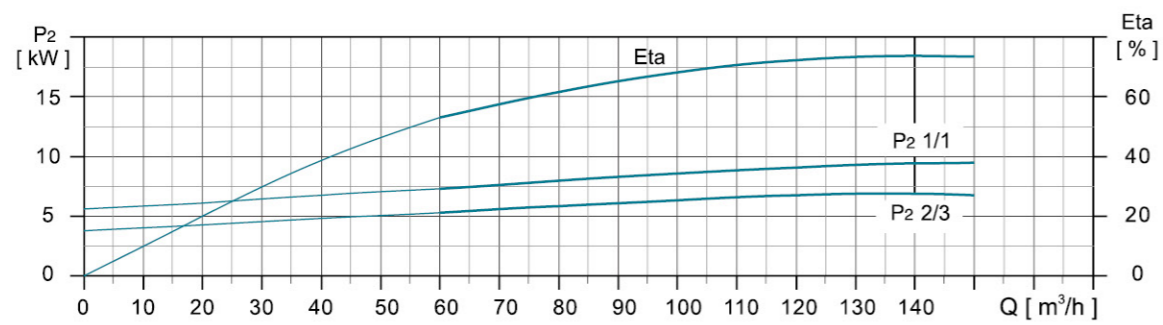
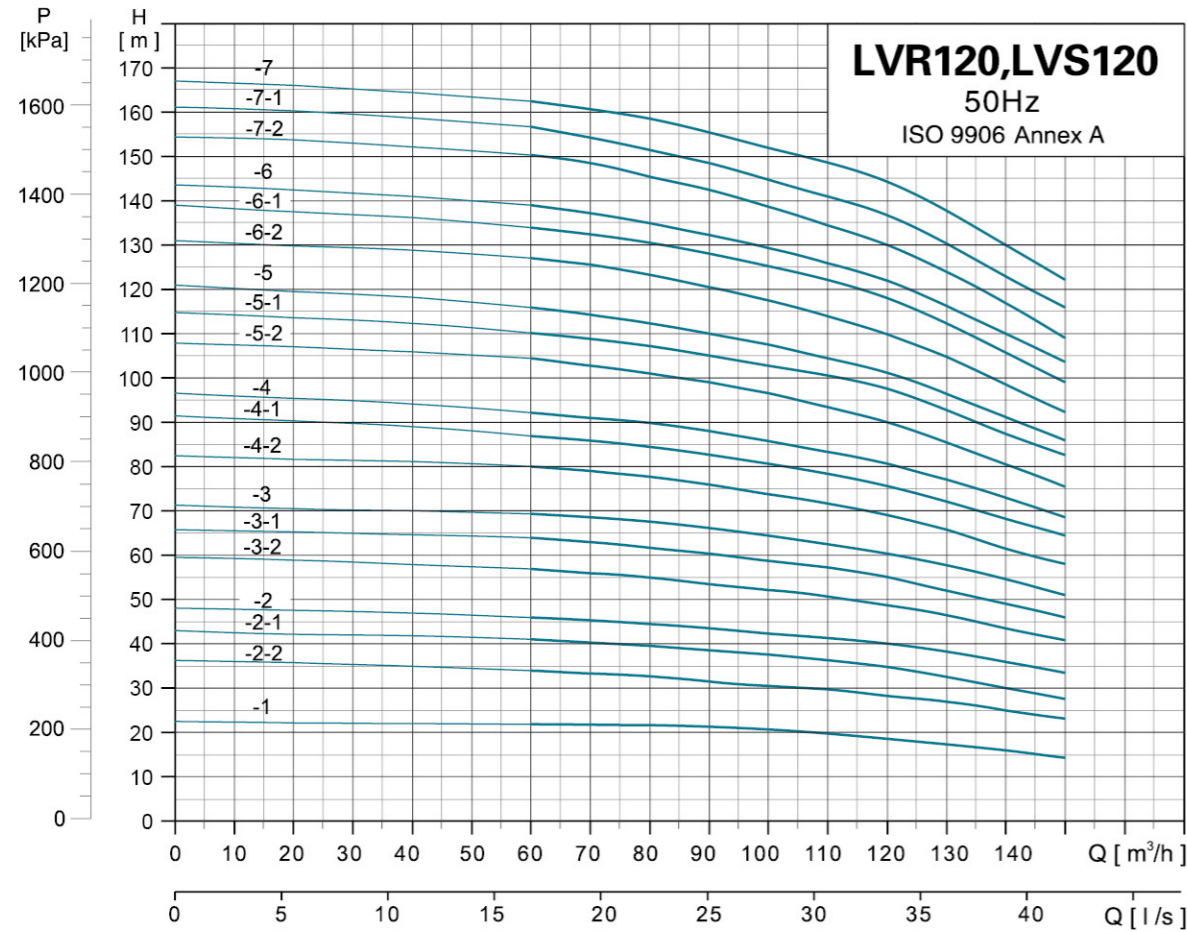

Dimension Drawing

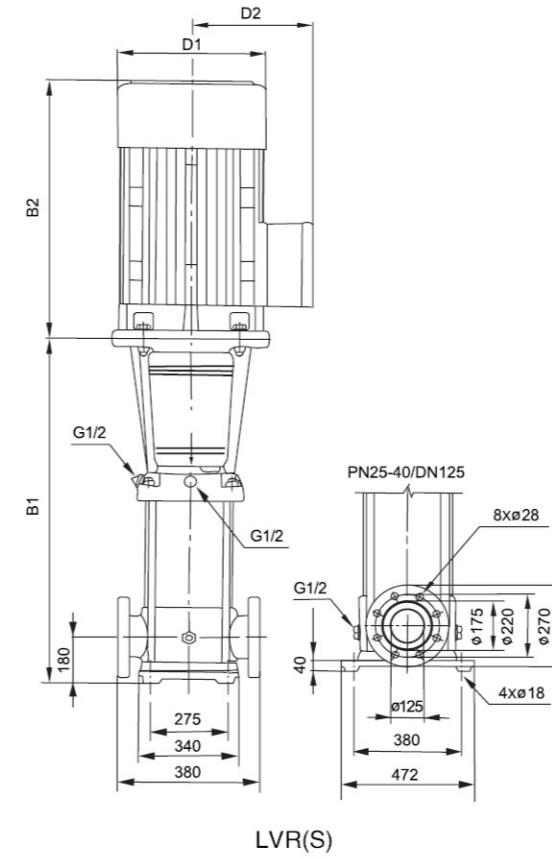

MODEL	DIN FLANGE(LVR, LVS)		D1	D2	N.W. (kgs)
	B1	B1+B2			
120-1	840	1339	254	175	186
120-2-2	1000	1499	254	175	210
120-2-1	1000	1560	330	250	250
120-2	1000	1600	380	280	285
120-3-2	1160	1840	420	305	326
120-3-1	1160	1840	420	305	360
120-3	1160	1840	420	305	360
120-4-2	1320	2000	420	305	400
120-4-1	1320	2000	420	305	400
120-4	1320	2035	470	335	460
120-5-2	1480	2195	470	335	470
120-5-1	1480	2195	470	335	470
120-5	1510	2295	510	370	575
120-6-2	1670	2455	510	370	585
120-6-1	1670	2455	510	370	585
120-6	1670	2515	580	410	705
120-7-2	1830	2675	580	410	715
120-7-1	1830	2675	580	410	715
120-7	1830	2675	580	410	715

MODEL	POWER[kW]	Q[m³/h]	H(m)												
			60	70	80	90	100	110	120	130	140	150			
LVR(S)120-1	11		22	21.8	21.6	21	20.5	19.5	18.5	17	16	15			
LVR(S)120-2-2	15		34	33.6	33	31	30.2	30	28.5	27	25	24			
LVR(S)120-2-1	18.5		41	40	39.5	38.5	37	36.5	34.5	32.5	30	27.5			
LVR(S)120-2	22		46	45	44.5	43.5	42.4	41	40	38	36	33.5			
LVR(S)120-3-2	30		57	56	55	53.5	52	51	49	46.5	43.5	41			
LVR(S)120-3-1	30		64	63	62	60	58.5	57.5	55.5	52	49	46			
LVR(S)120-3	30		69.5	68.5	67.5	66	64.4	62.5	61	57.5	54.5	51			
LVR(S)120-4-2	37		80.5	79	78	76	73.5	72	69	66	61.5	58			
LVR(S)120-4-1	37		87	86	84.5	82	80	78	76	72	68	64.5			
LVR(S)120-4	45		92.5	91	90	88	85.5	83	81	77	73	68.5			
LVR(S)120-5-2	45		104.5	103	101	99	96	93	90	85.5	80.5	75.5			
LVR(S)120-5-1	45		110.5	109	107.5	105	102	100	97	92	86.5	83			
LVR(S)120-5	55		115.5	114	113	110	107.5	104.5	101.5	96	91	86			
LVR(S)120-6-2	55		128	125.5	123	121	117.3	113.5	110	104.5	98.5	92.5			
LVR(S)120-6-1	55		134	132	130.5	127	124	121	118	111	105	100			
LVR(S)120-6	75		139	137	135	132	128.8	126	123	116	110	104			
LVR(S)120-7-2	75		151	148	145.5	143	138.6	134	130	123.5	116.5	109			
LVR(S)120-7-1	75		156.5	154	152	148.5	144.5	141	137.5	130	123	116.5			
LVR(S)120-7	75		162.5	160.5	158.5	155	151	148	145	137	129	123			

Hydraulic Performance Curves

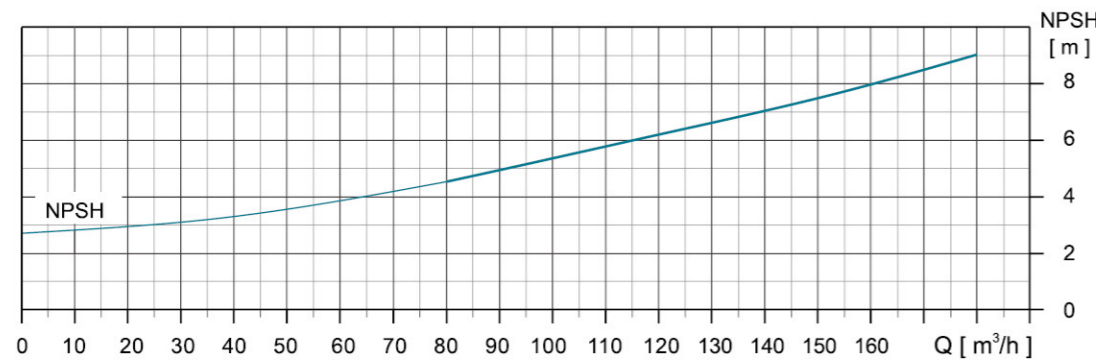
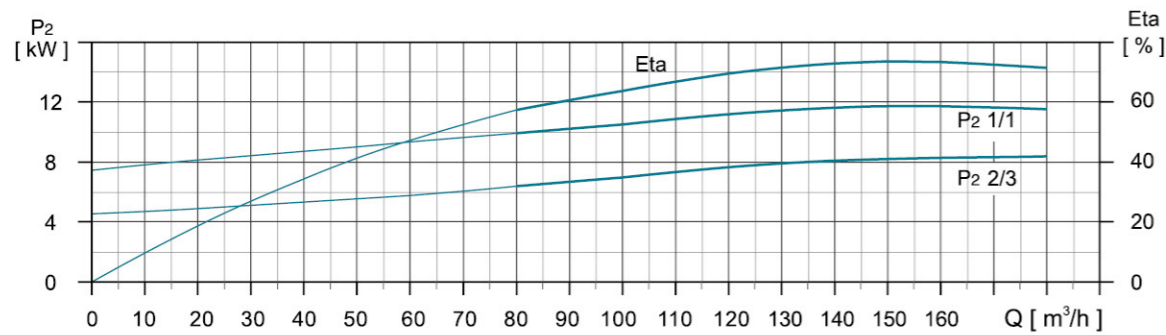
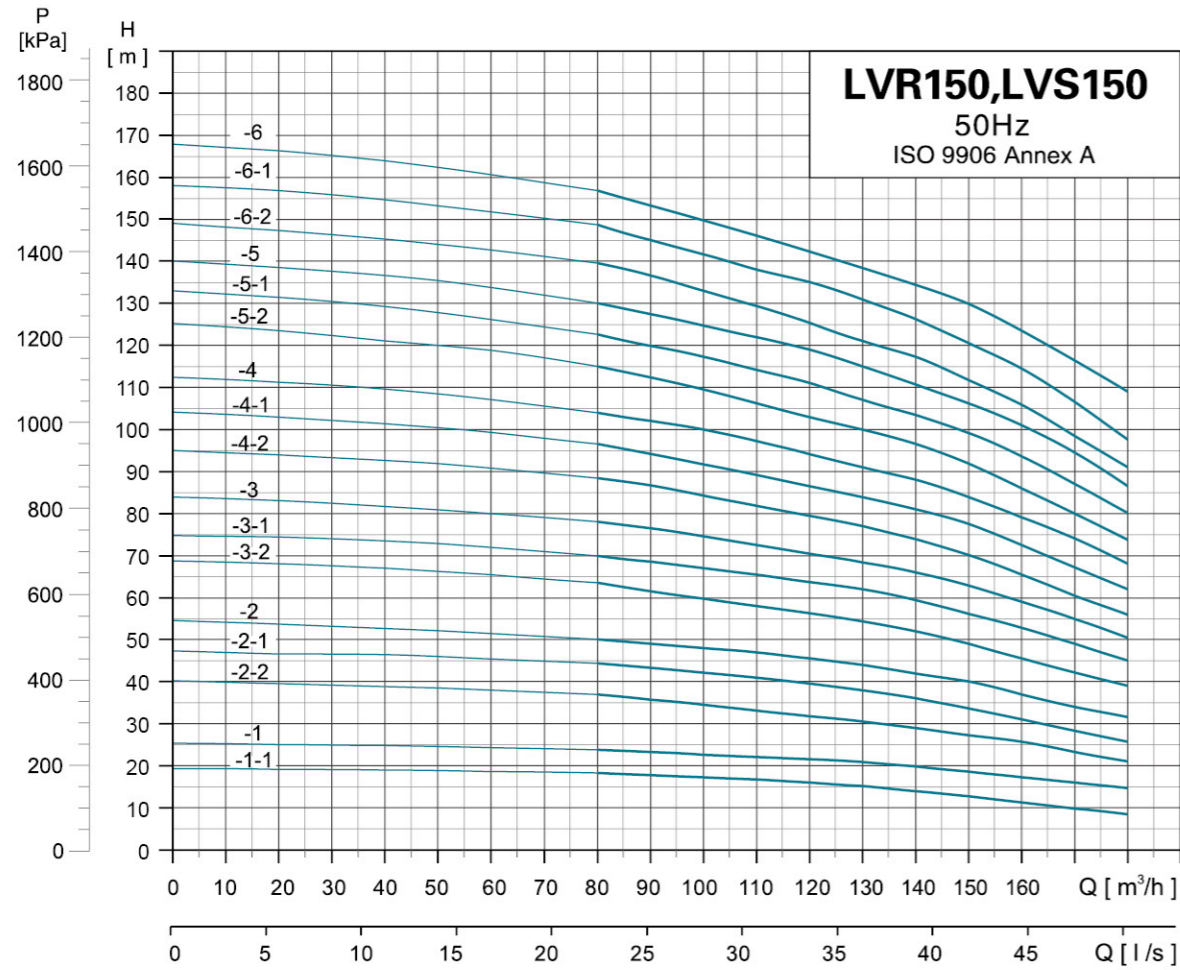

Dimension Drawing

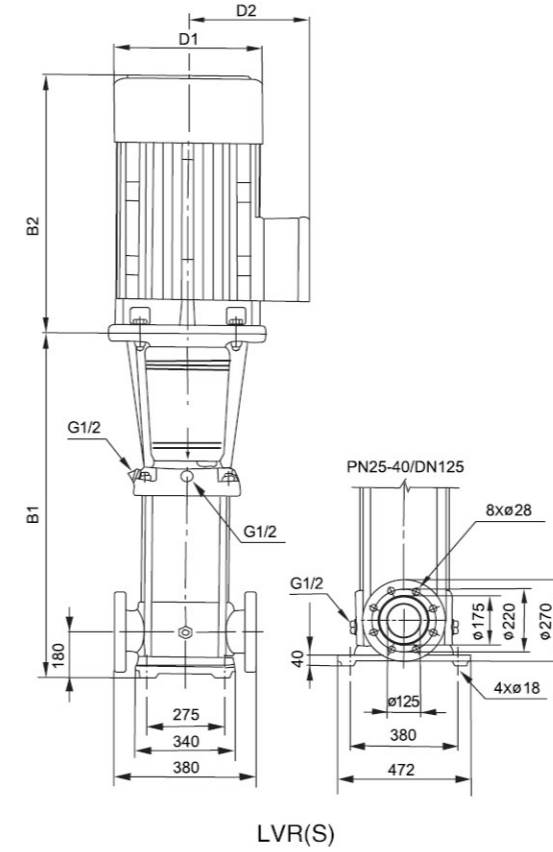

MODEL	DIN FLANGE(LVR, LVS)		D1	D2	N.W. (kgs)
	B1	B1+B2			
150-1-1	840	1339	254	175	186
150-1	840	1339	254	175	200
150-2-2	1000	1560	330	250	250
150-2-1	1000	1600	380	280	295
150-2	1000	1680	420	305	317
150-3-2	1160	1840	420	305	360
150-3-1	1160	1840	420	305	360
150-3	1160	1840	420	305	385
150-4-2	1320	2035	470	335	460
150-4-1	1320	2035	470	335	460
150-4	1350	2135	510	370	560
150-5-2	1510	2295	510	370	570
150-5-1	1510	2355	580	410	690
150-5	1510	2355	580	410	690
150-6-2	1670	2515	580	410	700
150-6-1	1670	2515	580	410	700
150-6	1670	2515	580	410	700

MODEL	POWER[kW]	Q[m³/h]	80	90	100	110	120	130	140	150	160	170	180
LVR(S)150-1-1	11	H(m)	18.3	17.8	17.3	17	16	15	14	12.5	11	10	8.5
LVR(S)150-1	15		24	23	22.5	22	21.5	20.5	20	18.5	17	16	15
LVR(S)150-2-2	18.5		37	35.5	34	33	32	31	29	27.5	26	23	21
LVR(S)150-2-1	22		44.3	43	42	40	39	38.5	37.5	35	33	30	27
LVR(S)150-2	30		50	49	48	47	45.5	44	42	40	37	34	32
LVR(S)150-3-2	30		63.5	61	59	57.5	56	54.5	53	49	45.5	42	39
LVR(S)150-3-1	37		70	68	67	65	63	62	60	56	53	49	45
LVR(S)150-3	37		78	76.5	75	73	70.5	68	66	63	59	55	50.5
LVR(S)150-4-2	45		89	87	84	81.5	79	77	74.5	70.5	65.5	60	56
LVR(S)150-4-1	45		96.5	94	91.5	89	86.5	84	81.5	77	72.5	67	62
LVR(S)150-4	55		104	102	100	97	95	91	88	84	79.5	74	68
LVR(S)150-5-2	55		115.5	112	109	106	102.5	100	97	92	86	79	73.5
LVR(S)150-5-1	75		122.5	119.5	117	113.5	111.5	107.5	104.5	99	93.5	87	80
LVR(S)150-5	75		130	127.5	125	121	119	115	111.5	106.5	101	94.5	86.5
LVR(S)150-6-2	75	140	137	133	130	126	121	118	112	106	98	91	
LVR(S)150-6-1	75	148.5	145	141.7	137.5	135	131	127	120.5	114.5	106.5	97.5	
LVR(S)150-6	75	157	153	149	145	142	139.5	137	130	123.5	116	109	

Hydraulic Performance Curves

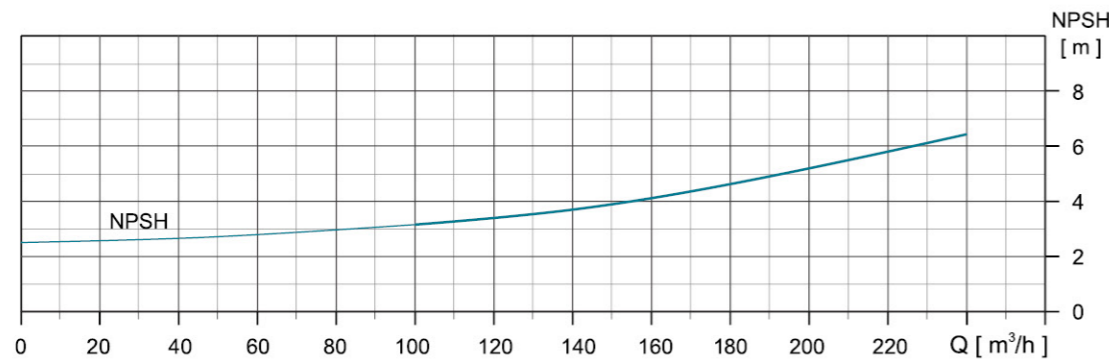
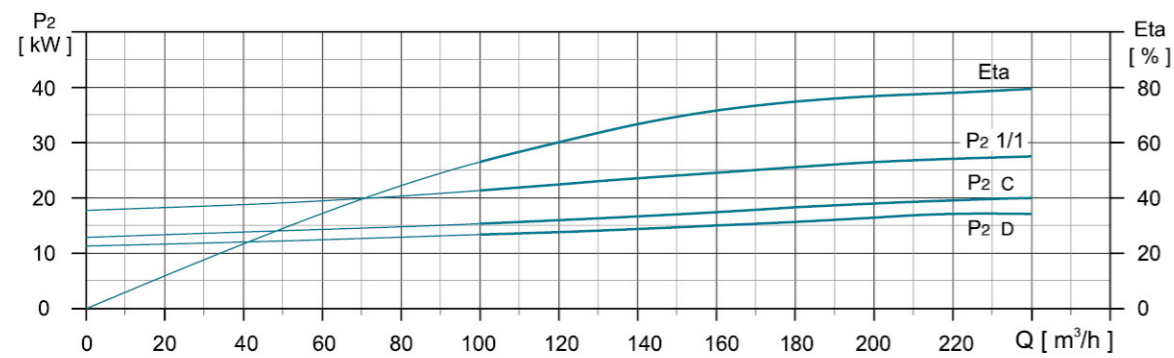
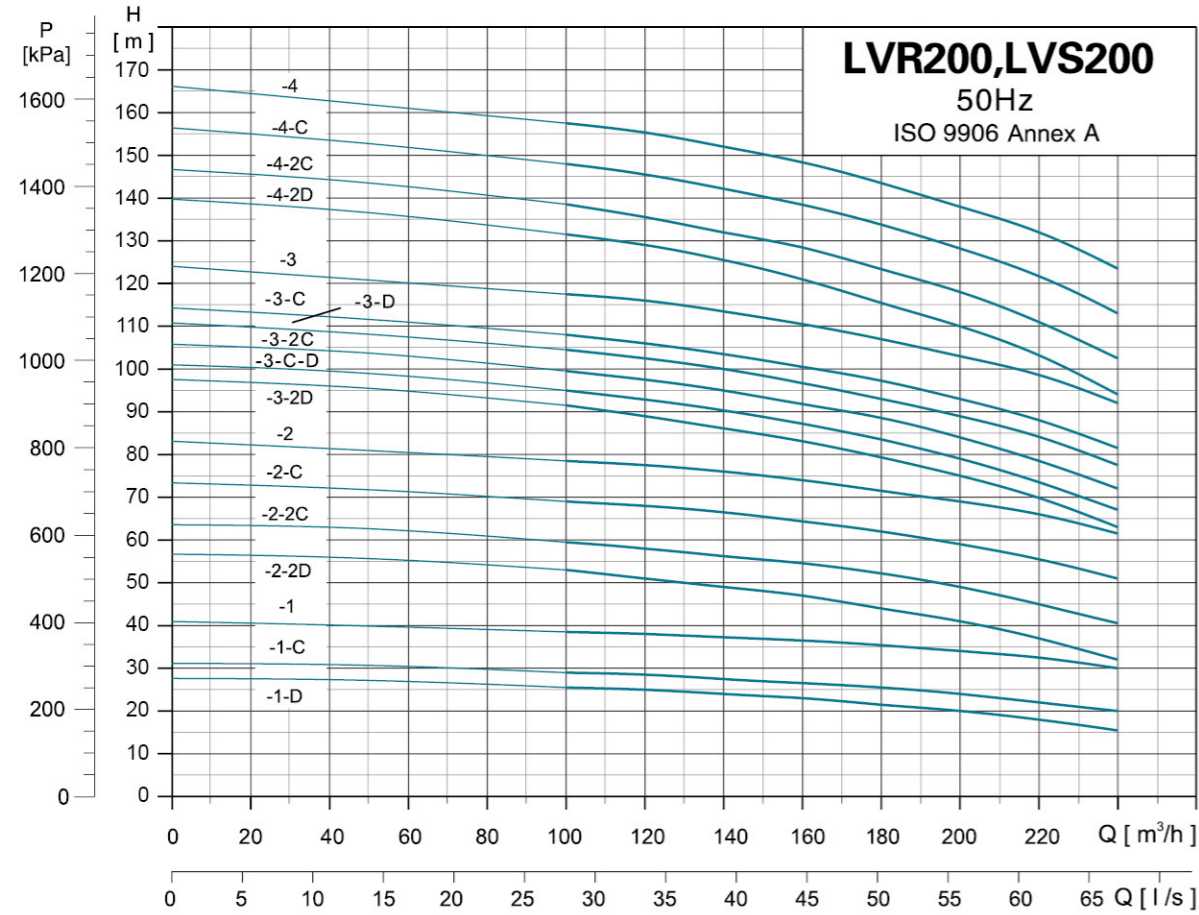

Dimension Drawing

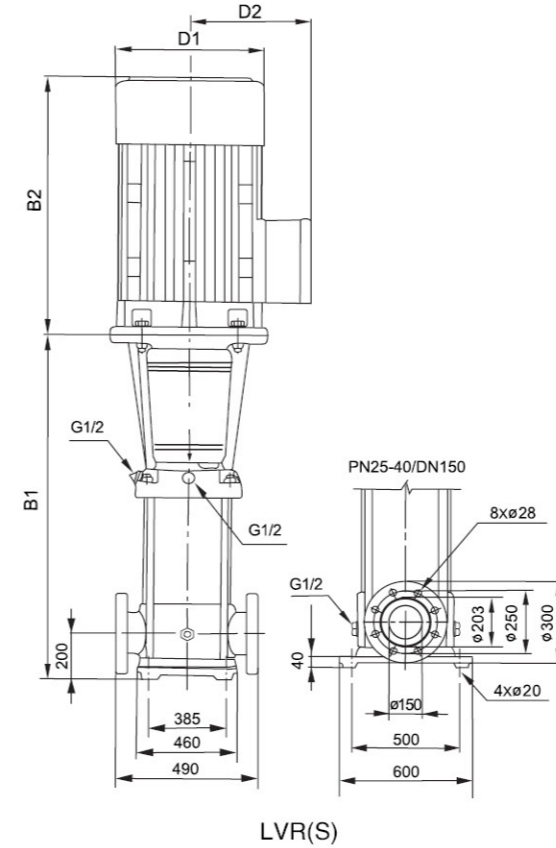

MODEL	DIN FLANGE(LVR, LVS)		D1	D2	N.W. (kgs)
	B1	B1+B2			
200-1-D	907	1467	330	250	311
200-1-C	907	1507	380	280	347
200-1	907	1587	420	305	403
200-2-2D	1101	1781	420	305	447
200-2-2C	1101	1816	470	335	504
200-2-C	1131	1916	510	370	595
200-2	1131	1916	510	370	595
200-3-2D	1325	2170	580	410	748
200-3-C-D	1325	2170	580	410	748
200-3-2C	1325	2170	580	410	748
200-3-D	1325	2170	580	410	748
200-3-C	1325	2170	580	410	748
200-3	1325	2220	580	410	817
200-4-2D	1519	2414	580	410	830
200-4-2C	1519	2619	645	530	1180
200-4-C	1519	2619	645	530	1180
200-4	1519	2619	645	530	1180

MODEL	POWER[kW]	Q[m³/h]	H(m)									
			100	120	140	160	180	200	220	240		
LVR(S)200-1-D	18.5		25.5	25	24	23	21.5	20	18	15.5		
LVR(S)200-1-C	22		29	28.5	27.5	26.5	25.5	24	22	20		
LVR(S)200-1	30		38.5	38	37.5	36.5	35	34	32.5	30		
LVR(S)200-2-2D	37		53	51	49	47	44	41	37	32		
LVR(S)200-2-2C	45		59.5	58	56	54	52.5	49	44.5	40.5		
LVR(S)200-2-C	55		69	68	66	64	62	59	55.5	51		
LVR(S)200-2	55		78.5	77.5	76	74	71.5	69	66	61.5		
LVR(S)200-3-2D	75		91.5	89	86.5	83.5	79	75	70	63		
LVR(S)200-3-C-D	75		95	93	90	87	83.5	79	73.5	67		
LVR(S)200-3-2C	75		99.5	97.5	94.5	91.5	89	84	78.5	72		
LVR(S)200-3-D	75		104.5	102.5	100	97	93	89	84.5	77.5		
LVR(S)200-3-C	75		108	106	103.5	100.5	97.5	93	88	81.5		
LVR(S)200-3	90		117.5	116	113.5	110.5	107	103	99	92		
LVR(S)200-4-2D	90		131.5	129	125.5	121	115.5	110	103.5	94		
LVR(S)200-4-2C	110		138.5	136	132	128	124	118	111	102.5		
LVR(S)200-4-C	110		148	145.5	142.5	138	134	128	122	113		
LVR(S)200-4	110		157.5	155.5	152.5	148	143.5	138	132.5	123.5		